



**MOTORCYCLE • OFF-ROAD • SCOOTER • ATV
TYRE FITMENT GUIDE**



Certificates of Quality

ISO 9001



European Economy Community
(E-mark) Certification

ISO 14001



TS16949



Taiwan Ministry of Economy
"A Quality Award"



CCC-Accredited of China
Compulsory Certification Mark



United States Department
of Transportation (DOT)

Maxxis International	2
Maxxis Tech. Centre	2
VIP Technology	3
Maxxis' Future	3
Technical Information	4 - 7
Supermaxx Sport	8
M6029 Supermaxx Touring	9
M6011 Classic	10
M6011 Whitewall	10
M6118 & M6119 Supermoto	11
C906 & C907 Hi-Max	11
MA-PD Detour	12
M6017 Traxer	12
Classic Road Tyres	13
M6029 Scooter Tyre	14
Other Premium Scooter Tyres	14 - 15
Moped Tyre	15
M7311 & M7312 Maxxcross Pro S/I Radial Soft Track	16
M7311 & M7312 Maxxcross Pro Soft/Inter Track	16
M7304 & M7305 Maxxcross Pro Inter Track	17
M7309 & M7310 Maxxcross Pro SX Hard/Inter Track	17
M7307 & M7308 Maxxcross Pro SM Sandmaster	18
M7313 & M7314 Maxxenduro F.I.M Approved	18
C6006 Dual Sport Trail	19
M858 Premium Trail	19
M943 & M944 iRazr Radial	20
M933 & M934 Razr2	20
M931 & M932 Razr	21
C9272 & C9273 Streetmaxx	21
M9028 Sur Trak	22
M917 & M918 Bighorn Radial	22
C983 Rubicon Oversize	23
C828 Wildcat	23
Street Tyre Sizes	24
Off-road Tyre Sizes	25
Scooter Tyre Sizes	26
ATV Tyre Sizes	27
Motorcycle Fitment Guide	28 - 56
Off-road Fitment Guide	57 - 60
Scooter Fitment Guide	61 - 64
ATV Fitment Guide	65 - 66

Maxxis International

A commitment to excellence, combined with the pursuit of superior performance, is the driving force behind **Maxxis**. We stand firmly in this belief and stand by everything that we produce. We are driven to meet our customers' needs and then to surpass their expectations.

Our passion for success began in 1967 and has since evolved into what is now **Maxxis**: a premium line of tyres designed for almost every application imaginable. Maxxis produces tyres for cars and motorcycles as well as for light trucks, karts, bicycles, all-terrain vehicles (ATVs), lawn and garden equipment, trailers and industrial equipment.

Every day **Maxxis** tyres face the most challenging conditions the World has to offer. They stand up to extreme weather conditions, battle the toughest terrain and win championships. They are continually put to the test and every time they succeed.

Over 20,000 individuals on three continents strive to make these tyres the best available. The results of our efforts are offered on the following pages.

Maxxis Tech. Centre

Safety, performance and premium quality are the top priorities for every tyre that we produce. To ensure these factors are present without exception, we employ unwavering technological standards. **Maxxis** tyres are tested meticulously throughout every stage of design and production, in all conceivable conditions. The equipment that we use for designing and manufacturing tyres ranks among the industry's finest and most advanced.

In order to further our commitment to these standards, we created the **Maxxis Tech. Centre** in Norcross, Georgia, which houses our American-based engineering staff. Our engineers around the World work closely with each other when designing and testing tyres so that they can provide each other with uninhibited feedback and suggestions to ensure every tyre meets our rigorous requirements. The quality of our tyres – a credit to our innovative technology – has been pivotal in the success and growth of **Maxxis**. We plan to maintain that success by continuing to manufacture and deliver products of the highest quality to the consumer.



VIP Technology

In order to test tyre concepts in the early design stages, **Maxxis** engineers created Virtual Intelligent Prototyping, or VIP Technology. This revolutionary process allows our scientists to predict a tyre's performance before it enters production. VIP Technology combines a series of computer-aided analysis programs that lay out a framework for each tyre's design. The system factors in pressure points at varying inflation levels and contact points to simulate cornering, acceleration, braking and the effects of strain and wear.

After the design concept passes careful VIP analysis, the tyre advances to the moulding stage. At this point a tyre mould is produced and a prototype tyre is created. This tyre is then run through a battery of laboratory tests by our engineering team.

A tyre passing the in-house trials then proceeds to the next level: field testing. Every tyre, whether designed for racing or industrial use, is subject to exacting tests in the field. Performance evaluation by our test riders is a crucial step in determining if and when a tyre will reach the public. Once a tyre reaches the market it remains subject to continuous evaluation and research throughout the product's life cycle.

Maxxis' Future

Continually looking to improve tyre performance, **Maxxis** is investing in our own private proving grounds in China. This test track, one of the few privately owned in China, will promote **Maxxis'** growing relationships with major auto makers. Construction of the new facility in Shanghai is expected to be complete in 2010.

The evaluations don't stop there. Our sponsored riders test our tyres and give input that directly affects the finished product.

*The bottom line: A **Maxxis** tyre is evaluated until we're confident it's the best product we can produce.*

Our tyres are proof that the best people, facilities and technology, combined with real-world input from riders, produce a superior product that earns the loyalty of our lifelong customers.

Our lifelong customers are our key to unlocking future success. The bond we build with the people who use our tyres is and will continue to be our top priority.



Technical Information

Types of Tyre

There are three tyre construction types:

- diagonal (cross) ply
- radial ply
- bias belted

These may be:

- tubeless (no tube required) or
- tube type (requiring inner tube)

All three construction types are manufactured in several tread profiles. Tread patterns and profiles are available for front and rear positions. Special tyres are available for sporting events, some of which are unsuitable for road use and are marked accordingly (normally NHS - Not for Highway Service).

Regulation Mixing of Tyres

The intermixing of radial, bias belted and diagonal cross-ply tyres has legal requirements and motorcyclists are advised to consult the Motor Vehicles (Construction and Use) regulations obtainable from Her Majesty's Stationery Office.

Recommended fitment:

- 1 Diagonal cross-ply front and rear.
- 2 Diagonal cross-ply front and bias belted rear.
- 3 Diagonal cross-ply front and radial rear.
- 4 Radial front and rear.
- 5 Bias belted front and rear.

Illegal fitment:

- 1 Radial front and diagonal cross-ply rear.
- 2 Bias belted front and diagonal cross-ply rear.
- 3 Radial front and bias belted rear.

Tyre Load and Speed Markings

Radial, bias belted, and diagonal (cross) ply tyres have markings to indicate their load and speed capabilities.

It is important that tyres are suitable for the maximum speed capability of the motorcycle. In some overseas countries this is a legal requirement.

Tyre speeds are shown in accordance with an alphabetical list of symbols indicating speeds at 10 kmh increments.

The relevant speed symbol is positioned near the size designation in conjunction with a load index: e.g. 120/90-18 65S, where '65' is the load index and 'S' the speed symbol. In the case of speed symbols 'V' and 'ZR', these are shown within the size designation, e.g. 120/90 V18. The size designation for 'V' and 'ZR' normally omits the load index. Details of speed symbols and load indices are shown in **tables 1** and **2**.

Watch Your Tread

Tyre treads are designed to give good wet grip but the road surface condition plays the major part in tyre to road adhesion. In general, wet grip decreases as tyre tread patterns wear down or as the depth of surface water increases. Motorcyclists should take this into consideration and reduce speed when it is wet.

The legal limit of tyre tread depth in the UK for motorcycles over 50cc is 1mm across $\frac{3}{4}$ of the width of the tread pattern and with visible tread on the remaining $\frac{1}{4}$. For motorcycles up to 50cc the law requires that all the grooves of the original tread pattern must be clearly visible. The legal requirements may differ in other countries.

Safety and Maintenance

Inflation pressures must be checked at least once a week. They should be checked only when the tyre is cold, since there is an increase in pressure when the tyre has warmed up after being run. A reliable pressure gauge should be used.

The recommended inflation pressures are vitally important for safe handling of the motorcycle. Pressures must be adjusted appropriately for solo and for pillion and pannier loads. It is dangerous to re-inflate a tyre which has been run flat or seriously under-inflated. Such tyres should be removed for inspection by a tyre specialist.

Tyres should be examined regularly, removing stones and other objects embedded in the tyre.

Oil or grease should be removed with a suitable diluted detergent.

Lumps or bulges could indicate internal damage and should be examined by a tyre specialist without delay.

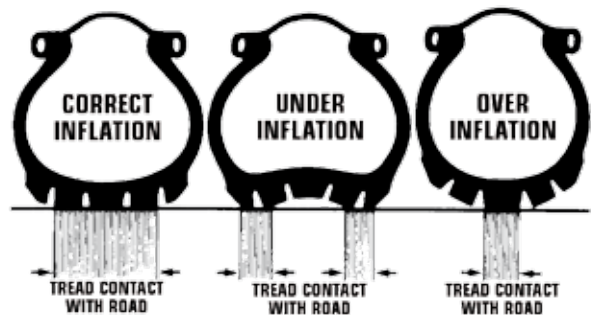

Table 1 :: Tyre Speed Markings

Speed Symbol	Maximum motorcycle speed for which the tyre is suitable	
	kmh	mph
Moped (B)	50	30
F	80	50
J	100	62
K	110	69
L	120	75
M	130	81
P (or -)	150	95
Q	160	100
R	170	105
S	180	113
T	190	118
U	200	125
H	210	130
V*	over 210	over 130
ZR*	over 240	over 150

*** The max approved speed may be marked on the tyre sidewall, for example: V230 meaning 230kmh max speed**

Age Deterioration

Tyres can deteriorate with age which shows as cracking of the tread and sidewall rubber, sometimes accompanied by carcass deformation. Cracking is usually an indication that tyres have been in service for an extremely long time, but rubber deterioration may be brought about by poor storage conditions. If cracking is severe, the tyre must be replaced.

Technical Information

Table 2 :: Tyre Load Indices & Relating Maximum Loads

Load Index	Load kg	Load Index	Load kg	Load Index	Load kg	Load Index	Load kg	Load Index	Load kg	Load Index	Load kg	Load Index	Load kg	Load Index	Load kg
20	80	30	106	40	140	50	190	60	250	70	335	80	450	90	600
21	82.5	31	109	41	145	51	195	61	257	71	345	81	462	91	615
22	85	32	112	42	150	52	200	62	265	72	335	82	475	92	630
23	87.5	33	115	43	155	53	206	63	272	73	365	83	487	93	650
24	90	34	118	44	160	54	212	64	280	74	375	84	500	94	670
25	92.5	35	121	45	165	55	218	65	290	75	387	85	515	95	690
26	95	36	125	46	170	56	224	66	300	76	400	86	530		
27	97	37	128	47	175	57	230	67	307	77	412	87	545		
28	100	38	132	48	180	58	236	68	315	78	425	88	560		
29	103	39	136	49	185	59	243	69	325	79	437	89	580		

Tubes

Ensure that the correct size and type is fitted, and that the valve stem tightly fits the hole in the rim. Always use a new tube when fitting a replacement tube type tyre or a tubeless tyre requiring an inner tube.

Tubes which are stretched, thinned or excessively repaired may deflate without warning and should not be re-fitted.

Tubes must always be used with tyres fitted to wire spoked wheels, irrespective of whether the tyre is tubeless or tube type, except for those wire spoked rims specifically designed for tubeless tyres. A rim band or a rim tape of the correct type must be fitted to protect the tube from spoke head damage.

Inner tubes of the correct size may only be used with tubeless tyres if correctly fitted, and approved by the individual tyre manufacturer. It must, however, be emphasised that the result of fitting tubes in tubeless tyres is that, in the event of a puncture, the assembly will behave in exactly the same way as a tube type tyre and tube assembly - i.e. it is likely to lose pressure more rapidly than a tubeless tyre assembly.

Where tubes for certain low profile tubeless tyres are not available, an alternative size tube should not be fitted.

Tyres which are marked 'Tube Type' or are not marked 'Tubeless' must be fitted with an inner tube.

Valves

A new valve should be fitted when replacing tubeless tyres. When checking or adjusting inflation pressure always ensure that the valve is not leaking.

The fitment of a valve core with a steel spring is necessary for high speed usage. Particular care must be taken to ensure that the valve is the correct size and type for the rim.

When a tube is fitted, and the rim valve hole is designed for a rubber snap-in tubeless valve, it will be necessary to fit an adapter collar or skirted lock nut to ensure correct valve location. Always fit a valve cap, preferably of the sealing type.

Repaired Tyres

Repairs to motorcycle tyres and tubes must be carried out in accordance with the current British Standard AU 159 and should, therefore, be entrusted to a specialist.

All punctured or damaged tyres must be removed from the wheel for internal and external examination to ensure there is no hidden damage which would cause a later failure.

In order to avoid such a hazard, neither externally applied plug tyre repairs nor liquid sealants are recommended and tyre manufacturers cannot be responsible for problems resulting from their use.

Wheels and Rims

It is essential that the wheel size and type is a suitable fitment for the tyre and motorcycle concerned (see **table 3**).

Tyres must not be used on damaged or distorted wheels since this could result in tyre damage and deflation.

Car and motorcycle rims of the same nominal diameter have different dimensions and therefore car and motorcycle rims and tyres must not be inter-changed.

Removal and Fitting of Tyres

These operations should be entrusted only to a tyre specialist who has the necessary equipment and expertise. Inexpert fitting can result in damaged tyres and wheels. Direction arrows, where shown on the sidewall, indicate the direction of rotation of front and rear tyres and must not be ignored.

General

Driving over pot-holes, kerbs or other obstructions, even at low speeds, can result in the weakening or fracture of the casing structure.

E-Marking

Motorcycle tyres will be supplied in accordance with 'The Motor Vehicle Tyre (Safety) Regulations 1994'.

Technical Information

Table 3 :: Wheel Rims

		Rim Size														
		1.20	1.35	1.5 WM0	1.6 WM1	1.85 WM2	MT1.85 2.15 WM3	MT2.15 MT2.5 2.50	MT2.75 2.75	MT3.00	MT3.5	MT4.0	MT4.5	MT5.0	MT5.25 MT5.5 MT5.75	
Tyre Aspect	100%	2.25	2.25 2.50	2.25 2.50 2.75	2.25 2.50 2.75 3.00 3.10	2.75 3.00 3.10 3.25 3.50 3.60	3.00 3.10 3.25 3.50 3.60	3.25 3.50 3.60 4.00 4.10	4.00 4.10	4.00 4.10 5.00	4.00					
	90%				80/90	80/90 90/90	80/90 90/90 100/90 110/90	90/90 100/90 110/90 120/90 130/90	100/90 110/90 120/90 130/90 140/90	110/90 120/90 130/90 140/90 150/90	130/90 140/90 150/90					
	80%						110/80	110/80 120/80 130/80	110/80 120/80 130/80 140/80	110/80 120/80 130/80 140/80 150/80	130/80 140/80 150/80 160/80	150/80 160/80	160/80			
	70%								110/70	110/70 120/70 130/70	110/70 120/70 130/70 140/70 150/70 160/70	130/70 140/70 150/70 160/70 170/70	140/70 150/70 160/70 170/70	160/70 170/70	170/70	
	60%										120/60 130/60	120/60 130/60 140/60 150/60 160/60	130/60 140/60 150/60 160/60 170/60	140/60 150/60 160/60 170/60	160/60 170/60	170/60
	55%															180/55
50%															190/50	

Tyre Conversion Chart

Imperial	Imperial 90% series	Metric 90% series	Metric 80% series
2.25	-	70/90	80/80
2.50	3.10	80/90	80/80 or 90/80
2.75	3.10	80/90	80/80 or 90/80
3.00	3.60	90/90	100/80
3.25	3.60	90/90	100/80
3.50	4.10	100/90	110/80
4.00	4.25, 4.60	110/90	120/80
4.25	4.70	120/90	130/80
4.50	5.10, 5.30	130/90	140/80
5.50	-	140/90	150/80
6.00	-	150/90	160/80

Sidewall Marking/Conversion

Marking	Metric equivalent	
	Front	Rear
ML	90	
MM	100 or 110	
MN	110	
MR	120	120
MP		120
MT	130	130
MU		140
MV		150

Tyre Aspect Ratio

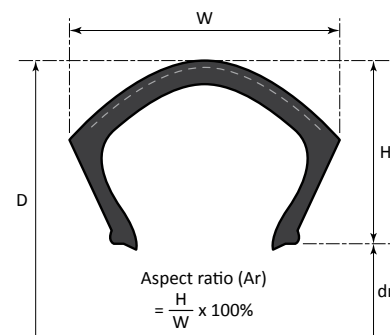

Aspect ratio is the tyre section height expressed as a percentage of the width

E E-marked
Motorcycle tyres will be supplied in accordance with 'The Motor Vehicle Tyre (Safety) Regulations 1994'

Technical Information

Size Markings

There are essentially three types of size marking used for motorcycle tyres:

- 1 Imperial
- 2 Imperial Low Profile
- 3 Millimetric

All of these systems describe the width (**W**), height (**H**) and rim diameter (**dr**) of a tyre size.

The drawing shows where these dimensions are measured from and the overall diameter (**D**).

The height of the tyre and hence its overall diameter (**D**) is controlled by the Aspect Ratio (**Ar**).

Tyre sizes for all motorcycle tyres, except those for specialised non-road legal applications, (pure racing tyres, ATV tyres, etc.) are expressed as:

Width/Aspect Ratio	Construction or Speed Symbol	Rim diameter
W/R		dr

For older Imperial sizes the Aspect Ratio is 100% and not shown.

For example:

3.50-18 = 3.50" wide, 3.50" tall - 18" rim diameter

For the older Imperial Low Profile series the Aspect Ratio was 90% but as the widths of the tyres were unique, it was not shown. Where the tyre width was not unique, or where the Aspect Ratio was not 90%, the actual Aspect Ratio was shown.

For example:

4.10-19, where 4.10 is a unique width

4.10" wide 4.10"x90% = 3.7" tall - 19" rim diameter

4.25/85-18, Where 4.25 is not a unique width and the Aspect Ratio is not 90%

4.25" wide/4.25x85% = 3.6" tall - 18" rim diameter

Perhaps the most easily understood size markings are the modern millimetric type.

For example:

110/90-18

110mm wide/110x90% = 99mm tall - 18" rim diameter

Although the mixing of Metric and Imperial units can, even in this case, cause some confusion.

The effect of changing the Aspect Ratio is to change the overall diameter of the tyre:

$$D = W \times Ar \times 2 + (25.4 \times dr)$$

Therefore:

$$120/100-18 \text{ D} = 120 \times 100\% \times 2 + (25.4 \times 18) = 697.2\text{mm}$$

$$120/90-18 \text{ D} = 120 \times 90\% \times 2 + (25.4 \times 18) = 673.2\text{mm}$$

$$120/80-18 \text{ D} = 120 \times 80\% \times 2 + (25.4 \times 18) = 649.2\text{mm}$$

Each of these tyres is 120mm wide and fitted on an 18" rim but as you can see there is a significant difference in the overall diameters.

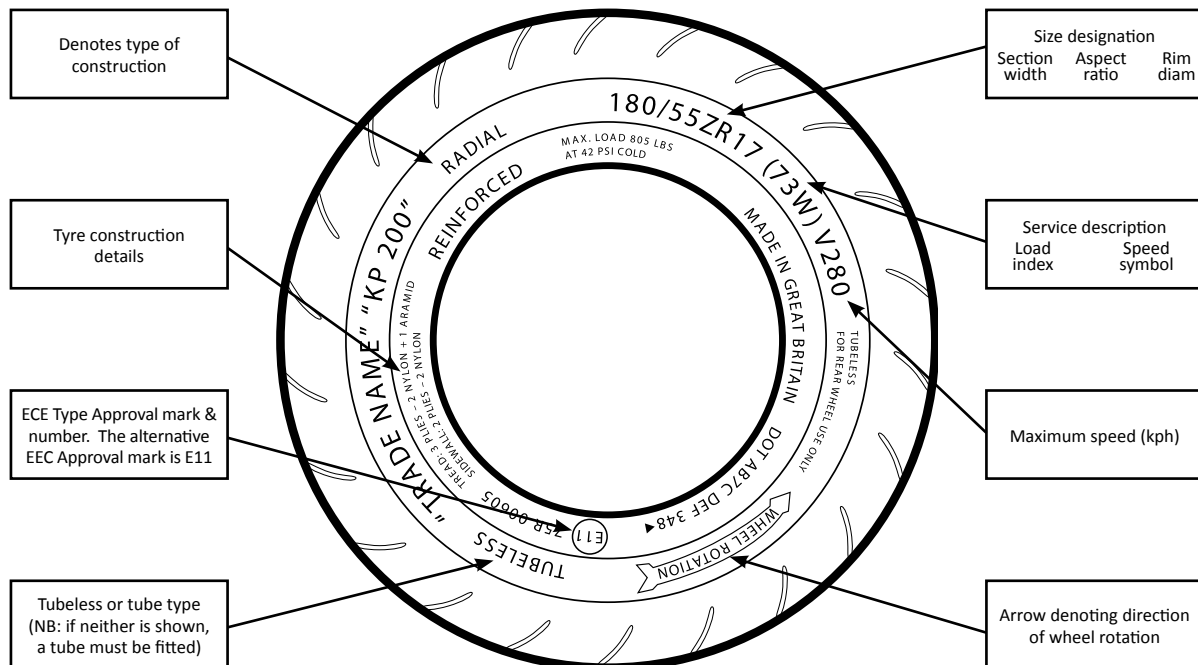

Supermaxx Sport



Maxxis introduces its updated high performance sport bike tyre to its product line-up – the next generation **Supermaxx Sport**. It features an advanced tread pattern and distinct, angular profile to allow quick, precise and responsive handling.

The silica compound, formulated for optimum traction in dry and wet conditions, allows for cooler running temperatures and maximum grip on both the track and street. Further more, the revolutionary radial carcass uses monospiral Kevlar® construction to maintain tyre uniformity at high speeds.

All combined, the new **Supermaxx Sport** is a sport bike tyre with track day performance.

- High performance radial tyre designed for the occasional track day and aggressive street rider
- Innovative tread design provides outstanding handling and cornering performance
- Silica compound provides traction when you need it most
- New carcass provides greater rider feedback

Front		Rear	
Size	L/S	Size	L/S
120/60-ZR17	55W	160/60-ZR17	69W
120/70-ZR17	58W	180/55-ZR17	73W
		190/50-ZR17	73W
		190/55-ZR17	73W



M6029 Supermaxx Touring

Maxxis has developed the M6029 Supermaxx Touring tyre using *Virtual Intelligent Prototyping* and *Finite Element Analysis (FEA)* – the most advanced computer technology.

FEA is used to ensure even load distribution between cornering and straight-line performance. This identifies the stress/load conditions that the tyre will be used under, ensuring that even distribution of load is achieved at maximum stress levels under force, whilst achieving a fast and controlled response.

The Supermaxx Touring has a distinctive profile and tread pattern which creates responsive handling and stability for quick and precise cornering. The revolutionary radial construction uses Kevlar® belts to ensure tyre uniformity at high speeds.



- A distinctive profile and tread pattern create precise handling and stability for quick and precise cornering
- W-rated for today's high performance sport bikes



Virtual Intelligent Prototyping 





The VIP idea was adopted from the beginning when, whilst engineering the prototype, the computer was used to simulate a virtual racing situation.

With this information, we have built a tyre that maintains greater manoeuvrability and traction in a straight line or during excessive turning.



MSB (Mono Spiral Belt)
The use of an MSB improves the strength of the tread and the evenness and roundness of the tyre, giving increased riding stability at high speed.

Front		Rear	
Size	L/S	Size	L/S
130/70-ZR16	61W	150/70-ZR17	69W
110/70-ZR17	54W	160/60-ZR17	69W
110/80-ZR17	57W	170/60-ZR17	72W
120/60-ZR17	55W	180/55-ZR17	73W
120/65-ZR17	56W	190/50-ZR17	73W
120/70-ZR17	58W	200/50-ZR17	75W

M6011 Classic



The specially formulated compound and matched front/rear tread pattern provide excellent traction and durability in dry and wet weather. Deep offset tread grooves channel water away from the contact patch. Additional stability is provided by the offset centre rib, which resists tracking over surface rain grooves and steel grated bridges.

A classic bike deserves a classic tyre!

M6011 Whitewall



Designed for classic styled machines, the **Maxxis M6011** is also available in a **Whitewall** option. The specially formulated compound and matched front/rear tread pattern provide excellent traction and durability in dry and wet weather. Deep offset tread grooves channel water away from the contact patch. Additional stability is provided by the offset centre rib, which resists tracking over surface rain grooves and steel grated bridges.

A classic bike deserves a classic tyre!

Front		Rear	
Size	L/S	Size	L/S
MT90-16	74H	150/80-15	70H
130/90-16	67H	150/90-15	74H
120/90-18	65H	170/80-15	77H
90/90-19	52H	MT90-16	74H
100/90-19	57H	130/90-16	73H
110/90-19	62H	140/90-16	77H
*MH90-21	56H		
MH90-21	56H		
80/90-21	48H		

*Model C926 TL

Front		Rear	
Size	L/S	Size	L/S
MT90-16	74H	170/80-15	77H
130/90-16	67H	140/90-15	70H
150/80-16	71H	150/90-15	74H
120/90-18	65H	MT90-16	74H
100/90-19	62H	130/90-16	73H
		140/90-16	77H
		150/80-16	71H

M6118 & M6119 Supermoto



The versatility of the **M6118** and **M6119** speaks for itself. Kevlar® belted construction ensures stability, while specially formulated compounds maintain optimum grip in a wide range of conditions.

- Unique tread design allows for use in a wide variety of conditions
- Low profile design offers larger contact patch under hard braking
- Specially formulated tread compound offers superior traction and confidence
- Kevlar® belted construction enhances performance and maintains tyre uniformity
- *E-marked street legal*

Front M6118		Rear M6119	
Size	L/S	Size	L/S
120/70-17	58S	160/60-17	69S

C906 & C907 Hi-Max



Give them a good look, because this pair of tyres have been designed and matched for one purpose — stable, high-speed touring in all weather conditions.

The low profiles and aggressive tread patterns give you a tenacious grip and an advanced, wear-resistant rubber compound meaning extra miles of worry-free thrills. The diagonal tread pattern is designed to allow more efficient water dispersion whilst maintaining good control in corners. With the special construction, this provides a safe and smooth ride at high speeds.

- H-rated tubeless

Front C906		Rear C907	
Size	L/S	Size	L/S
100/90-16	54H	130/90-15	66H
120/80-16	60H	140/90-15	70H
90/90-18	51H	120/90-16	63H
100/90-18	56H	130/90-16	67H
100/90-19	57H	150/80-16	71H
		130/90-17	68H
		90/90-18	51P
		100/90-18	56H
		110/90-18	61H
		120/80-18	62H
		120/90-18	65H
		130/80-18	66H

MA-PD Detour



Maxxis introduces its new radial **Adventure-Touring** tyre, the **Detour**. Available in V-Strom, BMW, and Triumph Tiger sizes, the **Detour** offers excellent and responsive handling in both wet or dry, on and off-road conditions.

The **Detour's** stable central blocks and large grooves easily disperse water and grip the road in a straight line and while weaving through the back roads, offering comfort and ease throughout your ride. With its unique compound, the new **Detour** will yield low tread wear to make your adventures seem endless!

- Stable central blocks with large grooves for outstanding water dispersion
- Optimised tread pattern creates a larger contact patch for increased cornering confidence and smooth transition
- Special formulated compounds yield low tread wear while offering outstanding traction

Front		Rear	
Size	L/S	Size	L/S
110/80-19	59H	150/70-17	69H

M6017 Traxer



The **Maxxis M6017 Traxer** is a tyre that enables you to ride in every condition, on or off-road. The curve of the footprint area provides stability at all lean angles. The V-groove tread pattern is designed to allow more efficient water and mud dispersion.

The important thickness of the tread design gives excellent comfort and enables a maximum speed of up to 130mph.

Front		Rear	
Size	L/S	Size	L/S
90/90-21	54H	130/80-17	65H
		140/80-17	69H

Classic Road Tyres



C107

C113

C117

C155

C180

C289

C-Rib

Front Only

Size	PR	Tread	L/S
2.50-17	4	C-Rib	38L
3.00-17	4	C-Rib	50J
2.75-18	4	C-Rib	42P
2.75-19	4	C116	-
3.00-18	4	C-Rib	47P
3.25-19	4	C-Rib	54P

Universal Front & Rear

Size	PR	Tread	L/S
3.00-16	4	C117	43N
3.50-16	6	C155	58P
3.50-16	4	C289	58P
4.60-16	4	C289	60
2.50-17	4	C107	38L
2.75-17	4	C117	-
3.00-17	4	C180	45N
3.25-17	4	C180	50N
3.50-17	4	C180	-
2.50-18	4	C113	40L
2.75-18	4	C117	42P
3.00-18	4	C180	50N
3.25-18	4	C117	53N
3.50-18	4	C117	-
4.00-18	6	C180	65N
2.75-19	4	C117	45P
3.00-19	2	C113	49N
3.50-19	4	C180	57N

M6029 Scooter Tyre



With its exceptional design, the **M6029** offers everything you need in a high performance tubeless scooter tyre. Providing outstanding grip, handling and stability, this tyre is also built to last with a high-quality rubber compound.

The low profile tread design increases the footprint area allowing optimum acceleration, cornering and braking power in wet and dry conditions.

The special crossed tread grooves provide excellent water dispersion and enhance the grip and stability of the tyre. The improved wide tread pattern design yields maximum mileage.

- Designed for today's high performance scooters
- Specially formulated rubber compound offers excellent grip and wear
- Distinctive tread pattern offers precise handling and stability

M6029		M6029	
Size	L/S	Size	L/S
90/90-10	50J	130/70-12	56L
100/80-10	52J	130/70-12	56P
100/90-10	56J	130/80-12	69J
110/80-10	58J	140/60-12	62L
120/70-10	54J	140/70-12	60J
120/90-10	56J	140/70-12	60P
130/70-10	59J	110/70-13	57L
130/90-10	61J	110/90-13	56P
120/70-11	50L	120/70-13	53L
130/70-11	60L	130/60-13	60J
90/90-12	44J	130/60-13	60L
110/80-12	61L	130/60-13	60P
120/70-12	51J	130/70-13	57P
120/70-12	51L	140/60-13	63L
120/70-12	58P	140/60-13	63P
120/80-12	65J	110/80-14	
130/70-12	56J		

Other Premium Scooter Tyres



M6112



M6120



M6127



M6128



M6135

Maxxis tyres are supplied as OE on Piaggio, Gilera, Yamaha, Malaguti, Sym, Kymco, Peugeot & Aprilia scooters

Universal			Universal		
Size	Pattern	L/S	Size	Pattern	L/S
110/80-14	M6127	59J	120/70-15	M6002	56R
120/70-14	M6112	55P	120/70-15	M6128	56P
140/60-14	M6002	64R	130/80-15	M6128	
140/60-14	M6128		100/80-16	M6120	50P
140/70-14	M6112	62L	110/70-16	M6135	52P
150/70-14	M6112	66S	120/80-16	M6128	60S

Other Premium Scooter Tyres



Universal		
Size	Pattern	L/S
2.50-8	C177	28J
3.00-8	C903	
2.75-10	C800	
3.00-10	C131	42J
3.50-10	C910	
3.50-10	C131	51J
80/90-10	C922	
90/90-10	C922	50J
120/90-10	C923	54J
130/90-10	C924	59J
3.00-12	C131	47J



C131 C800 C903 C910 C923 C924

Universal Moped		
Size	Pattern	PR
2.25-14	C109	2

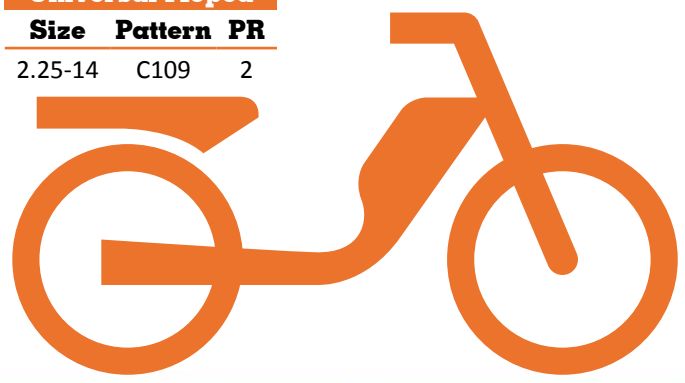

Moped Tyre



C109

M7311 & M7312 Maxxcross Pro S/I Radial Soft Track



The self-cleaning tread pattern and race-proven rubber compound deliver excellent traction and outstanding tyre wear in soft/intermediate conditions. The uniquely spaced tread pattern produces superior straight-line control and precise cornering, the bridged centre knobs provide predictability, control and excellent straight-line traction under acceleration whilst the optimised shoulder knob design gives incredible cornering stability.

- Radial construction provides a larger contact patch for faster and more controlled acceleration, braking and cornering, as well as increased ride comfort

Front M7311		Rear M7312	
Size	L/S	Size	L/S
80/100-21	51M	110/90-19	62M

M7311 & M7312 Maxxcross Pro Soft/Inter Track



The self-cleaning tread pattern and race-proven rubber compound deliver excellent traction and outstanding tyre wear in soft/intermediate conditions. The uniquely spaced tread pattern produces superior straight line control and precise cornering, the bridged centre knobs provide predictability, control and excellent straight-line traction under acceleration whilst the optimised shoulder knob design gives incredible cornering stability.

- Lightweight 2-ply construction
- Perfect for any soft to intermediate terrain

Front M7311		Rear M7312	
Size	L/S	Size	L/S
70/100-17	40M	3.00-10	40J
70/100-19	42M	90/100-14	49M
80/100-21	51M	90/100-16	52M
		100/100-18	59M
		110/100-18	64M
		120/100-18	88M
		100/90-19	57M
		110/90-19	62M
		120/90-19	66M

M7304 & M7305 Maxxcross Pro Inter Track



A unique knob and groove tread design offers exceptional handling through intermediate conditions. An advanced rubber compound enhances straight-line traction for maximum control. The reinforced sidewall offers excellent stability and torque wrenching performance while the tread blocks offer excellent traction. The combination of **M7304** front with the **M7305** rear offers uncompromised straight line and cornering balance.

- New knob design offers precise steering for a wide variety of soil conditions
- Lightweight 2-ply construction

Front M7304		Rear M7305	
Size	L/S	Size	L/S
2.50-10	33J	2.75-10	38J
2.50-12	42J	80/100-12	50M
60/100-14	30M	90/100-14	49M
70/100-17	40M	90/100-16	51M
70/100-19	42M	100/100-17	58M
90/100-20	56M	100/100-18	59M
80/100-21	51M	110/100-18	64M
		120/100-18	68M
		100/90-19	57M
		110/90-19	62M
		120/90-19	66M

M7309 & M7310 Maxxcross Pro SX Hard/Inter Track



Maxxis introduces the latest **Maxxcross SX**. Developed and tested for use in Supercross and Arena-cross conditions, the **SX** features a newly developed soft rubber compound offering unrivalled traction in hard-packed conditions.

Maxxis is proud of this product and is sure their riders will be excited with the results as well. The new **Maxxcross SX** is further proof that **Maxxis** is taking performance to the next level.

- Delivers outstanding performance on intermediate to hard terrain
- Optimal pattern design offers increased contact patch and exceptional straight-line stability

Front M7309		Rear M7310	
Size	L/S	Size	L/S
80/100-21	51M	100/90-19	57M
		110/90-19	62M

M7307 & M7308 Maxxcross Pro SM Sandmaster



The **Sandmaster** is an exclusive sand and mud tyre that combines a mud-repelling, silica-based rubber compound with a computer-enhanced tread design. In addition to its specially formulated compound, the **Sandmaster** tyre also incorporates anti-flex knob bridges on the shoulder, increasing traction and stability.

- Computer-enhanced pattern design ensures optimal traction in sand and mud
- Specially formulated silica rubber compound and open tread pattern provide excellent self-cleaning tyre characteristics
- Anti-flex knob bridges on shoulder reinforce side knobs for increased traction

Front M7307		Rear M7308	
Size	L/S	Size	L/S
80/100-21	51M	110/100-18	64M
		120/100-18	68M
		100/90-19	57M
		110/90-19	62M
		120/90-19	66M

M7313 & M7314 Maxxenduro F.I.M Approved



Maxxis introduces its new versatile **M7313** and **M7314 MaxxEnduro** which is an E-marked road legal tyre, ideal for most enduro conditions.

The side blocks provide accurate steering in muddy conditions and are designed for aggressive cornering even in the deepest of mud.

Front M7313		Rear M7314	
Size	L/S	Size	L/S
80/100-21		120/90-18	
90/90-21	54R	140/80-18	70R

C6006 Dual Sport Trail



The **Maxxis Dual Sport Trail C6006** offers superior performance on and off-road. A unique directional tread pattern delivers a smooth ride on level terrain, while a lower knob ratio enhances traction for off-road applications.

- 70% knob-to-groove ratio delivers smooth performance on the highway while adding excellent grip on off-road surfaces
- Unique tread block design offers an excellent self-cleaning effect, providing riders quick access when going from off-road to street surfaces
- Designed for large dual-purpose bikes

C6006	
Size	L/S
130/80-17	65P
120/80-18	62P
130/80-18	66P
2.75-21	45P
90/90-21	54P

C858 Premium Trail



- Ideal tyre for a budget priced replacement
- Popular on-/off-road pattern which makes this an excellent tyre for on-road/off-road riding
- Special knobs penetrate loose surfaces

C858	
Size	L/S
3.00-16	45P
4.60-17	-
3.00-18	-
3.50-18	56P
4.10-18	-
4.60-18	-
2.50-21	43L
2.75-21	48P
3.00-21	-

M943 & M944 iRazr Radial



The iRazr's radial construction offers a smoother and more controlled ride by reducing bump steer and arm fatigue, giving riders that extra edge. Radial construction also reduces the sidewall tension of the tyre, allowing a wider contact patch with the terrain and better braking performance.

- Radial construction increases ride comfort and minimises effect of braking bumps
- Innovative tread pattern and flat profile provides excellent braking and steering response
- Designed for optimum performance in all MX conditions

Front M943

Size	PR	PSI	Load
21 x 7.00-R10	6	9	235
22 x 7.00-R10	6	9	255

Rear M944

Size	PR	PSI	Load
20 x 11.00-R9	6	7	340
20 x 11.00-R10	6	7	330

M933 & M934 Razr2



The 6-ply rating makes the Razr2 suitable for all types of terrain. The Razr2's increased depth and angled tread offers improved steering and braking. With the Razr and Razr2, Maxxis offers the best set-up for the serious cross country racer on every track and weather condition known to man.

- Aggressive tread pattern for enhanced cornering
- Increased lug depth offers increased skid and traction control
- E-marked street legal

Front M933

Size	PR	PSI	L/S
21 x 7.00-10	6	9	30J
22 x 7.00-10	6	9	33J
23 x 7.00-10	6	9	36J

Rear M934

Size	PR	PSI	L/S
20 x 11.00-9	6	7	43J
22 x 11.00-9	6	7	48J
20 x 11.00-10	6	7	42J
22 x 11.00-10	6	7	47J

M931 & M932 Razr

C9272 & C9273 Streetmaxx



Since its inception, the **Maxxis Razr** has changed the face of Cross Country ATV racing. The **Razr** has been a mainstay among top riders in many series.

- Front tyre features a raised centre ridge to provide precise steering, while side knob placement offers superb handling and cornering capability
- Specially formulated racing compound delivers superior traction while extending tread life
- Solid knob design improves traction and reduces tread squirm

The comprehensive **Maxxis** range of ATV and sports quad tyres includes the **C9272** and the **C9273 Streetmaxx** which have the benefit of being E-marked and, therefore, street legal.

- E-marked street legal
- Speed index rating N (86mph/140kph)

Front M931

Size	PR	PSI	L/S
21 x 7.00-10	4	9	25J
22 x 7.00-10	4	9	28J
22 x 8.00-10	4	9	31J

Rear M932

Size	PR	PSI	L/S
18 x 10.00-8	2	7	22J
20 x 11.00-8	4	7	38J
20 x 11.00-9	4	7	38J
20 x 11.00-10	4	7	37J

Front C9272

Tyre size	PSI	L/S
19 x 7.0-8	7	20N
20 x 7.0-10	6	27N
21 x 7.0-10	12	42N
25 x 8.0-12	6	40N

Rear C9273

Tyre size	PSI	L/S
19 x 8.0-8	7	24N
20 x 10.0-9	12	50N
22 x 10.0-9	12	56N
18 x 10.0-10	6	32N
22 x 10.0-10	12	55N
25 x 10.0-12	6	50N

M9208 Sur Trak



The **Sur Trak** was designed to perform under the most demanding conditions. Dual traction lugs channel loose soil away from the contact patch to provide optimum grip. In addition, the **Sur Trak** features a durable nylon carcass to improve puncture resistance.

- Multi-directional tread design delivers traction in mud, snow, and sand
- Outside shoulder lugs provide aggressive side bite
- E-marked street legal

Universal	
Size	L/S
22 x 11.00-8	36J
22 x 11.00-9	36J
25 x 12.00-9	28J
22 x 11.00-10	35J
23 x 8.00-11	26J
24 x 8.00-11	36J
24 x 9.00-11	33J
24 x 10.00-11	29J
25 x 8.00-12	31J
25 x 10.00-12	38J

M917 & M918 Bighorn Radial



The tread pattern and wide footprint give this radial exceptional traction. The **Bighorn's** shoulder lugs protect the side-walls. Solid raised white lettering gives this tyre an attractive look. With radial construction, recreational riders as well as ATV racers will immediately appreciate the ride quality and comfort.

- Radial construction offers a significantly smoother ride over rough trails
- Extra lugs on the shoulder protect the sidewall and rim
- Tyre is suitable for desert, dirt and rock application

Front M917			
Size	PR	PSI	Load
25 x 8.00-R12	6	9	340

Rear M918			
Size	PR	PSI	Load
25 x 10.00-R12	6	7	420
26 x 12.00-R12	6	7	520

C983 Rubicon Oversize



Oversize conversion tyres are for ultimate performance in arduous conditions while still using standard wheel rims.

The powerful Rubicon **C983 Rubicon** gets you through the most rugged terrain you will face. Its wide, self-cleaning hook and bar tread design offers plenty of traction and power to tackle the toughest mud and steepest hills.

With a computer-designed tread pattern for maximum performance and a rugged rubber compound, the **C983 Rubicon** lets you take on brutal conditions and obstacles that might defeat other tyres.

Universal			
Size	PR	PSI	Load
25 x 12.50-11	2	5	430
25 x 9.50-12	2	5	340
25 x 12.50-12	2	5	430
26 x 12.00-12	6	5	550

C828 Wildcat



Ideal for Local Authority and agricultural machines where road use between sites is often necessary.

The **C828 Wildcat** features aggressive style lugs for superior traction.

- Large range of sizes available
- Speed index rating J (62mph/100kph)
- E-marked street legal

Universal			
Size	PSI	Load	L/S
22 x 11.00-8	5	309	36J
22 x 11.00-9			36J
25 x 12.00-9			44J
25 x 13.00-9	5	430	54J
22 x 8.00-10	3	176	24J
22 x 11.00-10	3	240	35J
24 x 11.00-10	4	310	40J
25 x 11.00-10			41J
25 x 12.00-10	4	355	44J
22 x 7.00-11	3	172	20J
23 x 8.00-11	4	210	26J
24 x 9.00-11	3	253	33J
24 x 8.00-11	4	225	29J
24 x 10.00-11	4	275	36J
24 x 8.00-12			28J
25 x 8.00-12	3	214	31J
25 x 10.00-12	3	260	38J



Street Tyre Sizes

Size	L/S	Pattern	Position	Tube
Street Tyres 15"				
130/90-15	66H	C907 Hi-Max	Rear	TL
140/90-15	70H	M6011 Whitewall	Rear	TL
140/90-15	70H	C907 Hi-Max	Rear	TL
150/80-15	70H	M6011 Classic	Rear	TL
150/90-15	74H	M6011 Classic	Rear	TL
150/90-15	74H	M6011 Whitewall	Rear	TL
170/80-15	77H	M6011 Classic	Rear	TL
170/80-15	77H	M6011 Whitewall	Rear	TL

Size	L/S	Pattern	Position	Tube
Street Tyres 16"				
3.00-16	43N	C117	Universal	TT
3.50-16	58P	C155	Universal	TT
3.50-16	58P	C289	Universal	TL
4.60-16	60	C289	Universal	TT
MT90-16	74H	M6011 Classic	Front	TL
MT90-16	74H	M6011 Whitewall	Front	TL
MT90-16	74H	M6011 Classic	Rear	TL
MT90-16	74H	M6011 Whitewall	Rear	TL
100/90-16	54H	C906 Hi-Max	Front	TL
120/80-16	60H	C906 Hi-Max	Front	TL
120/90-16	63H	C907 Hi-Max	Rear	TL
130/70-16	61W	M6029 Supermaxx Touring	Front	TL
130/90-16	67H	M6011 Classic	Front	TL
130/90-16	67H	M6011 Whitewall	Front	TL
130/90-16	73H	M6011 Classic	Rear	TL
130/90-16	73H	M6011 Whitewall	Rear	TL
130/90-16	67H	C907 Hi-Max	Rear	TL
140/90-16	77H	M6011 Classic	Rear	TL
140/90-16	77H	M6011 Whitewall	Rear	TL
150/80-16	71H	M6011 Whitewall	Front	TL
150/80-16	71H	M6011 Whitewall	Rear	TL
150/80-16	71H	C907 Hi-Max	Rear	TL

Size	L/S	Pattern	Position	Tube
Street Tyres 17"				
2.50-17	38L	C-Rib	Front	TT
2.50-17	38L	C107	Universal	TT
2.75-17	-	C117	Universal	TT
3.00-17	50J	C-Rib	Front	TT
3.00-17	46P	C180	Universal	TT
3.25-17	50N	C180	Universal	TT
3.50-17	-	C180	Universal	TT
110/70-17	54W	M6029 Supermaxx Touring	Front	TL
110/80-17	57W	M6029 Supermaxx Touring	Front	TL
120/60-17	55W	Supermaxx Sport	Front	TL
120/60-17	55W	M6029 Supermaxx Touring	Front	TL
120/65-17	56W	M6029 Supermaxx Touring	Front	TL
120/70-17	58W	Supermaxx Sport	Front	TL
120/70-17	58W	M6029 Supermaxx Touring	Front	TL
120/70-17	58S	M6118 Supermoto	Front	TL
130/80-17	65H	M6017 Traxer	Rear	TT
130/90-17	68H	C907 Hi-Max	Rear	TL
150/70-17	69W	M6029 Supermaxx Touring	Rear	TL
150/70-17	69H	MA-D Detour	Rear	TL
140/80-17	69H	M6017 Traxer	Rear	TT

Size	L/S	Pattern	Position	Tube
Street Tyres 17" continued				
160/60-17	69W	Supermaxx Sport	Rear	TL
160/60-17	69W	M6029 Supermaxx Touring	Rear	TL
160/60-17	69S	M6119 Supermoto	Rear	TL
170/60-17	72W	M6029 Supermaxx Touring	Rear	TL
180/55-17	73W	Supermaxx Sport	Rear	TL
180/55-17	73W	M6029 Supermaxx Touring	Rear	TL
190/50-17	73W	Supermaxx Sport	Rear	TL
190/50-17	73W	M6029 Supermaxx Touring	Rear	TL
190/55-17	73W	Supermaxx Sport	Rear	TL
200/50-17	75W	M6029 Supermaxx Touring	Rear	TL

Size	L/S	Pattern	Position	Tube
Street Tyres 18"				
2.50-18	40L	C113	Universal	TT
2.75-18	42P	C-Rib	Front	TT
2.75-18	42P	C117	Universal	TT
3.00-18	47P	C-Rib	Front	TT
3.00-18	-	C180	Universal	TT
3.25-18	53N	C117	Universal	TT
3.50-18	50N	C180	Universal	TT
4.00-18	65N	C180	Universal	TT
90/90-18	51H	C906 Hi-Max	Front	TL
90/90-18	51P	C907 Hi-Max	Rear	TL
100/90-18	56H	C906 Hi-Max	Front	TL
100/90-18	56H	C907 Hi-Max	Rear	TL
110/90-18	61H	C907 Hi-Max	Rear	TL
120/80-18	62H	C907 Hi-Max	Rear	TL
120/90-18	65H	M6011 Classic	Front	TL
120/90-18	65H	M6011 Whitewall	Front	TL
120/90-18	65H	C907 Hi-Max	Rear	TL
130/80-18	66H	C907 Hi-Max	Rear	TL

Size	L/S	Pattern	Position	Tube
Street Tyres 19"				
2.75-19	45P	C117	Universal	TT
3.00-19	49N	C113	Universal	TT
3.25-19	54P	C-Rib	Front	TT
3.50-19	57N	C180	Universal	TT
90/90-19	52H	M6011 Classic	Front	TL
100/90-19	57H	M6011 Classic	Front	TL
100/90-19	62H	M6011 Whitewall	Front	TL
100/90-19	57H	C906 Hi-Max	Front	TL
110/80-19	59H	MA-D Detour	Front	TL
110/90-19	62H	M6011 Classic	Front	TL

Size	L/S	Pattern	Position	Tube
Street Tyres 21"				
MH90-21	56H	M6011 Classic	Front	TL
80/90-21	48H	M6011 Classic	Front	TL
90/90-21	54H	M6017 Traxer	Front	TT

Off Road Tyre Sizes

Size	L/S	Pattern	Position	Tube
Off Road Tyres 10"				
2.50-10	33J	M7304 Maxxcross Pro IT	Front	TT
2.75-10	38J	M7305 Maxxcross Pro IT	Rear	TT
3.00-10	40J	M7312 Maxxcross Pro SI	Rear	TT

Size	L/S	Pattern	Position	Tube
Off Road Tyres 12"				
2.50-12	42J	M7304 Maxxcross Pro IT	Front	TT
80/100-12	50M	M7305 Maxxcross Pro IT	Rear	TT

Size	L/S	Pattern	Position	Tube
Off Road Tyres 14"				
3.00-14	-	C186 Premium Trail	Universal	TT
60/100-14	30M	M7304 Maxxcross Pro IT	Front	TT
90/100-14	49M	M7301 Maxxcross Pro HT	Rear	TT
90/100-14	49M	M7305 Maxxcross Pro IT	Rear	TT
90/100-14	49M	M7312 Maxxcross Pro SI	Rear	TT

Size	L/S	Pattern	Position	Tube
Off Road Tyres 16"				
3.00-16	45P	C858 Premium Trail	Universal	TT
90/100-16	51M	M7301 Maxxcross Pro HT	Rear	TT
90/100-16	51M	M7305 Maxxcross Pro IT	Rear	TT
90/100-16	52M	M7312 Maxxcross Pro SI	Rear	TT

Size	L/S	Pattern	Position	Tube
Off Road Tyres 17"				
3.00-17	45N	C186 Premium Trail	Universal	TT
4.60-17	-	C858 Premium Trail	Universal	TT
70/100-17	40M	M7300 Maxxcross Pro HT	Front	TT
70/100-17	40M	M7304 Maxxcross Pro IT	Front	TT
70/100-17	40M	M7311 Maxxcross Pro SI	Front	TT
100/100-17	58M	M7305 Maxxcross Pro IT	Rear	TT
130/80-17	65P	C6006 Dual Sport Trail	Universal	TT

Size	L/S	Pattern	Position	Tube
Off Road Tyres 18"				
3.00-18	-	C858 Premium Trail	Universal	TT
3.50-18	56P	C858 Premium Trail	Universal	TT
4.00-18	64N	C186 Premium Trail	Universal	TT
4.10-18	-	C858 Premium Trail	Universal	TT
4.60-18	-	C858 Premium Trail	Universal	TT
100/100-18	59M	M7301 Maxxcross Pro HT	Rear	TT
100/100-18	59M	M7305 Maxxcross Pro IT	Rear	TT
100/100-18	59M	M7312 Maxxcross Pro SI	Rear	TT
110/100-18	64M	M7301 Maxxcross Pro HT	Rear	TT
110/100-18	64M	M7305 Maxxcross Pro IT	Rear	TT
110/100-18	64M	M7308 Maxxcross Pro SM	Rear	TT
110/100-18	64M	M7312 Maxxcross Pro SI	Rear	TT
120/80-18	62P	C6006 Dual Sport Trail	Universal	TT
120/90-18		M7134 Maxxenduro FIM	Rear	TT
120/100-18	68M	M7301 Maxxcross Pro HT	Rear	TT
120/100-18	68M	M7305 Maxxcross Pro IT	Rear	TT
120/100-18	68M	M7308 Maxxcross Pro SM	Rear	TT
120/100-18	88M	M7312 Maxxcross Pro SI	Rear	TT
130/80-18	66P	C6006 Dual Sport Trail	Universal	TT
140/80-18	70R	M7314 Maxxenduro FIM	Rear	TT

Size	L/S	Pattern	Position	Tube
Off Road Tyres 19"				
2.50-19	41N	C186 Premium Trail	Universal	TT
3.00-19	50N	C186 Premium Trail	Universal	TT
70/100-19	42M	M7300 Maxxcross Pro HT	Front	TT
70/100-19	42M	M7304 Maxxcross Pro IT	Front	TT
70/100-19	42M	M7311 Maxxcross Pro SI	Front	TT
100/90-19	57M	M7301 Maxxcross Pro HT	Rear	TT
100/90-19	57M	M7305 Maxxcross Pro IT	Rear	TT
100/90-19	57M	M7308 Maxxcross Pro SM	Rear	TT
100/90-19	57M	M7310 Maxxcross Pro SX	Rear	TT
100/90-19	57M	M7312 Maxxcross Pro SI	Rear	TT
110/90-19	62M	M7301 Maxxcross Pro HT	Rear	TT
110/90-19	62M	M7305 Maxxcross Pro IT	Rear	TT
110/90-19	62M	M7308 Maxxcross Pro SM	Rear	TT
110/90-19	62M	M7310 Maxxcross Pro SX	Rear	TT
110/90-19	62M	M7312 Maxxcross Pro SI	Rear	TT
120/90-19	66M	M7301 Maxxcross Pro HT	Rear	TT
120/90-19	66M	M7305 Maxxcross Pro IT	Rear	TT
120/90-19	66M	M7308 Maxxcross Pro SM	Rear	TT
120/90-19	66M	M7312 Maxxcross Pro SI	Rear	TT

Size	L/S	Pattern	Position	Tube
Off Road Tyres 20"				
90/100-20	56M	M7304 Maxxcross Pro IT	Front	TT

Size	L/S	Pattern	Position	Tube
Off Road Tyres 21"				
2.50-21	43L	C858 Premium Trail	Universal	TT
2.75-21	45P	C6006 Dual Sport Trail	Universal	TT
2.75-21	48P	C858 Premium Trail	Universal	TT
3.00-21	-	C858 Premium Trail	Universal	TT
80/100-21	51M	M7300 Maxxcross Pro HT	Front	TT
80/100-21	51M	M7304 Maxxcross Pro IT	Front	TT
80/100-21	51M	M7307 Maxxcross Pro SM	Front	TT
80/100-21	51M	M7309 Maxxcross Pro SX	Front	TT
80/100-21	51M	M7311 Maxxcross Pro SI	Front	TT
90/90-21	54R	M7313 Maxxenduro FIM	Front	TT
90/90-21	54P	C6006 Dual Sport Trail	Universal	TT



Scooter Tyre Sizes

Size	L/S	Pattern	Position	Tube
Scooter Tyres 8"				
2.50-8	28J	C177	Universal	TT
3.00-8		C903	Universal	TT

Size	L/S	Pattern	Position	Tube
Scooter Tyres 10"				
2.75-10	37	C800	Universal	TT
3.00-10	42J	C131	Universal	TT
3.50-10	51J	C131	Universal	TT
3.50-10		C910	Universal	TL
80/90-10		C922	Universal	TT
90/90-10	50J	M6029	Universal	TL
90/90-10	50J	C922	Universal	TT
100/80-10	52J	M6029	Universal	TL
100/90-10	56J	M6029	Universal	TL
110/80-10	58J	M6029	Universal	TL
120/70-10	54J	M6029	Universal	TL
120/90-10	56J	M6029	Universal	TL
120/90-10	54J	C923	Universal	TL
130/70-10	59J	M6029	Universal	TL
130/90-10	61J	M6029	Universal	TL
130/90-10	59J	C924	Universal	TL

Size	L/S	Pattern	Position	Tube
Scooter Tyres 11"				
120/70-11	50L	M6029	Universal	TL
130/70-11	60L	M6029	Universal	TL

Size	L/S	Pattern	Position	Tube
Scooter Tyres 12"				
3.00-12	47J	C131	Universal	TT
90/90-12	44J	M6029	Universal	TL
110/80-12	61L	M6029	Universal	TL
120/70-12	51J/51L/ 58P	M6029	Universal	TL
120/80-12	65J	M6029	Universal	TL
130/70-12	56J/56L/ 56P	M6029	Universal	TL
130/80-12	69J	M6029	Universal	TL
140/60-12	62L	M6029	Universal	TL
140/70-12	60J/60P	M6029	Universal	TL

Size	L/S	Pattern	Position	Tube
Scooter Tyres 13"				
110/70-13	57L	M6029	Universal	TL
110/90-13	56P	M6029	Universal	TL
120/70-13	53L	M6029	Universal	TL
130/60-13	60J/60L/ 60P	M6029	Universal	TL
130/70-13	57P	M6029	Universal	TL
140/60-13	63L/63P	M6029	Universal	TL

Size	L/S	Pattern	Position	Tube
Scooter Tyres 14"				
2.25-14	24B	C109	Universal	TT
110/80-14		M6029	Universal	TL
110/80-14		M6127	Universal	TL
120/70-14		M6112	Universal	TL
140/60-14		M6002	Universal	TL
140/60-14		M6128	Universal	TL
140/70-14		M6112	Universal	TL
150/70-14		M6112	Universal	TL

Size	L/S	Pattern	Position	Tube
Scooter Tyres 15"				
120/70-15	56R	M6002	Universal	TL
120/70-15		M6128	Universal	TL
130/80-15		M6128	Universal	TL

Size	L/S	Pattern	Position	Tube
Scooter Tyres 16"				
100/80-16		M6120	Universal	TL
110/70-16		M6135	Universal	TL
120/80-16		M6128	Universal	TL
275/80-16		M6115	Universal	TL
325/80-16		M6116	Universal	TL

ATV Tyre Sizes

Size	Pattern	Ply	L/S	Position
Quad/ATV Tyres 6"				
145/70-6	C829	2PR		Universal

Size	Pattern	Ply	L/S	Position
Quad/ATV Tyres 7"				
16 x 8.00-7	C829	2PR	9J	Universal

Size	Pattern	Ply	L/S	Position
Quad/ATV Tyres 8"				
19 x 7.00-8	C9272 Streetmaxx		20N	Front
19 x 8.00-8	C9273 Streetmaxx		24N	Rear
18 x 10.00-8	M932 Razr	4PR	22J	Rear
20 x 7.00-8	C829	2PR	16J	Universal
20 x 11.00-8	M932 Razr	4PR	38J	Rear
22 x 11.00-8	C828 Wildcat	2PR	36J	Universal
22 x 11.00-8	M9208 Sur Trak	2PR	36J	Universal

Size	Pattern	Ply	L/S	Position
Quad/ATV Tyres 9"				
20 x 10.00-9	C9273 Streetmaxx		50N	Rear
22 x 10.00-9	C9273 Streetmaxx		56N	Rear
20 x 11.00-9	M944 iRazr Radial	6PR		Rear
20 x 11.00-9	M934 Razr2	6PR	43J	Rear
20 x 11.00-9	M932 Razr	4PR	38J	Rear
21 x 11.00-9	M944 iRazr Radial	6PR		Rear
22 x 11.00-9	M934 Razr2	6PR	48J	Rear
22 x 11.00-9	C828 Wildcat	2PR	36J	Universal
22 x 11.00-9	M9208 Sur Trak	2PR	36J	Universal
25 x 12.00-9	C828 Wildcat	2PR	44J	Universal
25 x 12.00-9	M9208 Sur Trak	2PR	28J	Universal
25 x 13.00-9	C828 Wildcat	2PR	54J	Universal

Size	Pattern	Ply	L/S	Position
Quad/ATV Tyres 10"				
20 x 6.00-10	M931 Razr	4PR	16J	Front
20 x 7.00-10	C9272 Streetmaxx		27N	Front
21 x 7.00-10	M943 iRazr Radial	6PR		Front
21 x 7.00-10	M933 Razr2	6PR	30J	Front
21 x 7.00-10	M931 Razr	4PR	25J	Front
21 x 7.00-10	C9272 Streetmaxx		42N	Front
21 x 7.00-10	C873	2PR		Universal
22 x 7.00-10	M943 iRazr Radial	6PR		Front
22 x 7.00-10	M933 Razr2	6PR	33J	Front
22 x 7.00-10	M931 Razr	4PR	28J	Front
23 x 7.00-10	M933 Razr2	6PR	36J	Front
22 x 8.00-10	M931 Razr	4PR	31J	Front
22 x 8.00-10	C828 Wildcat	2PR	24J	Universal
18 x 10.00-10	C9273 Streetmaxx		32N	Rear
22 x 10.00-10	C9273 Streetmaxx		55N	Rear
20 x 11.00-10	M934 Razr2	6PR	42J	Rear
20 x 11.00-10	M932 Razr	4PR	37J	Rear
22 x 11.00-10	M934 Razr2	6PR	47J	Rear
22 x 11.00-10	C828 Wildcat	2PR	35J	Universal
22 x 11.00-10	M9208 Sur Trak	2PR	35J	Universal
24 x 11.00-10	C828 Wildcat	2PR	40J	Universal
25 x 11.00-10	C828 Wildcat	2PR	41J	Universal
25 x 12.00-10	C828 Wildcat	2PR	44J	Universal

Size	Pattern	Ply	L/S	Position
Quad/ATV Tyres 11"				
22 x 7.00-11	C828 Wildcat	2PR	20J	Universal
23 x 8.00-11	C828 Wildcat	2PR	26J	Universal
23 x 8.00-11	M9208 Sur Trak	2PR	26J	Universal
24 x 8.00-11	C828 Wildcat	2PR	29J	Universal
24 x 8.00-11	M9208 Sur Trak	2PR	36J	Universal
24 x 9.00-11	C828 Wildcat	2PR	33J	Universal
24 x 9.00-11	M9208 Sur Trak	2PR	33J	Universal
24 x 10.00-11	C828 Wildcat	2PR	28J	Universal
24 x 10.00-11	M9208 Sur Trak	2PR	29J	Universal
25 x 12.50-11	C983 Rubicon Oversize	2PR		Universal

Size	Pattern	Ply	L/S	Position
Quad/ATV Tyres 12"				
25 x 8.00-12	M917 Bighorn Radial	6PR	43N	Front
25 x 8.00-12	C9272 Streetmaxx		40N	Front
24 x 8.00-12	C828 Wildcat	2PR	28J	Universal
25 x 8.00-12	C828 Wildcat	2PR	31J	Universal
25 x 8.00-12	M9208 Sur Trak	2PR	31J	Universal
25 x 9.50-12	C983 Rubicon Oversize	2PR		Universal
25 x 10.00-12	C9273 Streetmaxx		50N	Rear
25 x 10.00-12	M918 Bighorn Radial	6PR	50N	Rear
25 x 10.00-12	C828 Wildcat	2PR	38J	Universal
25 x 10.00-12	M9208 Sur Trak	2PR	38J	Universal
26 x 12.00-12	M918 Bighorn Radial	6PR	58N	Rear
26 x 12.00-12	C983 Rubicon Oversize	6PR		Universal
25 x 12.50-12	C983 Rubicon Oversize	2PR		Universal

Motorcycle Fitment Guide

Model	Front	Pattern	Rear	Pattern
Aprilia				
MX50 Supermoto	100/80-17		130/70-17	
Red Rose 50	2.75-18	C-Rib C117	120/90-16	
AF1 125 Extrema/Futura	110/70-17		140/70-17	
MX125	110/70-17		150/60-17	
Pegaso 125	90/100-19		120/90-17	
Red Rose 125	3.00-19	C113	130/90-16	
RS125 /Tuono	110/70-17		150/60-17	
125 Sintesi Replica	110/70-17		130/70-17	
Sport Pro 125	100/80-17		130/70-17	
SX125	110/70-17		150/60-17	
RS250	110/70-17		150/60-17	
SXV450/550	120/70-17	Supermaxx Sport M6029 Supermaxx Touring	180/55-17	Supermaxx Sport M6029 Supermaxx Touring
Pegaso 600	100/90-19	M6011 Classic C906 Hi-Max	130/80-17	M6017 Traxer C6006 Dual Sport Trail
Moto 6.5	100/90-18	C906 Hi-Max	130/90-17	C907 Hi-Max
Pegaso 650 /i.e./Garda/Trail	100/90-19		130/80-17	M6017 Traxer C6006 Dual Sport Trail
Pegaso 650 Factory	120/70-17	M6118 Supermoto Supermaxx Sport M6029 Supermaxx Touring	160/60-17	M6119 Supermoto Supermaxx Sport M6029 Supermaxx Touring
Pegaso 650 Strada	110/70-17	M6029 Supermaxx Touring	160/60-17	M6119 Supermoto Supermaxx Sport M6029 Supermaxx Touring
SL750 Shiver	120/70-17	Supermaxx Sport M6029 Supermaxx Touring	180/55-17	Supermaxx Sport M6029 Supermaxx Touring
SMV750 Dorsoduro	120/70-17	Supermaxx Sport M6029 Supermaxx Touring	180/55-17	Supermaxx Sport M6029 Supermaxx Touring
NA850 Mana	120/70-17	Supermaxx Sport M6029 Supermaxx Touring	180/55-17	Supermaxx Sport M6029 Supermaxx Touring
ETV1000 Caponord	110/80-19	MA-D Detour	150/70-17	MA-D Detour
Mille Tuono/Racing	120/70-17	Supermaxx Sport M6029 Supermaxx Touring	190/50-17	Supermaxx Sport M6029 Supermaxx Touring
RST1000 Futura	120/70-17	Supermaxx Sport M6029 Supermaxx Touring	180/55-17	Supermaxx Sport M6029 Supermaxx Touring
RSV Mille	120/70-17	Supermaxx Sport M6029 Supermaxx Touring	190/50-17	Supermaxx Sport M6029 Supermaxx Touring
RSV1000 R/Factory	120/70-17	Supermaxx Sport M6029 Supermaxx Touring	190/50-17	Supermaxx Sport M6029 Supermaxx Touring
RSV4 R/Factory	120/70-17	Supermaxx Sport M6029 Supermaxx Touring	190/55-17	Supermaxx Sport
Tuono /Factory	120/70-17	Supermaxx Sport M6029 Supermaxx Touring	190/50-17	Supermaxx Sport M6029 Supermaxx Touring
SL1000 Falco	120/70-17	Supermaxx Sport M6029 Supermaxx Touring	180/55-17	Supermaxx Sport M6029 Supermaxx Touring
Benelli				
500 LS	90/90-18	C906 Hi-Max	110/90-18	C907 Hi-Max
654 Sport/T	100/90-18	C906 Hi-Max	110/90-18	C907 Hi-Max
750 Sei	100/90-18	C906 Hi-Max	120/90-18	C907 Hi-Max
900 Sei	100/90-18	C906 Hi-Max	120/90-18	C907 Hi-Max
Tornado Novocento Tre 900	120/70-17	Supermaxx Sport M6029 Supermaxx Touring	190/50-17	Supermaxx Sport M6029 Supermaxx Touring
Tornado Tre 900 RS	120/70-17	Supermaxx Sport M6029 Supermaxx Touring	190/50-17	Supermaxx Sport M6029 Supermaxx Touring

Motorcycle Fitment Guide

Model	Front	Pattern	Rear	Pattern
Benelli continued				
Tornado Tre 900 LE	120/70-17	Supermaxx Sport M6029 Supermaxx Touring	180/55-17	Supermaxx Sport M6029 Supermaxx Touring
TNT 1130	120/70-17	Supermaxx Sport M6029 Supermaxx Touring	190/50-17	Supermaxx Sport M6029 Supermaxx Touring
Tre-K 1130	120/70-17	Supermaxx Sport M6029 Supermaxx Touring	180/55-17	Supermaxx Sport M6029 Supermaxx Touring
Bimota				
BB1	120/70-17	Supermaxx Sport M6029 Supermaxx Touring	160/60-17	Supermaxx Sport M6029 Supermaxx Touring
DB2	120/70-17	Supermaxx Sport M6029 Supermaxx Touring	180/55-17	Supermaxx Sport M6029 Supermaxx Touring
Mantra DB3	120/70-17	Supermaxx Sport M6029 Supermaxx Touring	180/55-17	Supermaxx Sport M6029 Supermaxx Touring
DB4	120/70-17	Supermaxx Sport M6029 Supermaxx Touring	180/55-17	Supermaxx Sport M6029 Supermaxx Touring
DB5	120/70-17	Supermaxx Sport M6029 Supermaxx Touring	180/55-17	Supermaxx Sport M6029 Supermaxx Touring
DB6	120/70-17	Supermaxx Sport M6029 Supermaxx Touring	180/55-17	Supermaxx Sport M6029 Supermaxx Touring
DB7	120/70-17	Supermaxx Sport M6029 Supermaxx Touring	190/55-17	Supermaxx Sport
SB6/SB6 R	120/70-17	Supermaxx Sport M6029 Supermaxx Touring	180/55-17	Supermaxx Sport M6029 Supermaxx Touring
SB7	120/70-17	Supermaxx Sport M6029 Supermaxx Touring	180/55-17	Supermaxx Sport M6029 Supermaxx Touring
SB8/SB8 R	120/70-17	Supermaxx Sport M6029 Supermaxx Touring	190/50-17	Supermaxx Sport M6029 Supermaxx Touring
YB4 ei	120/70-17	Supermaxx Sport M6029 Supermaxx Touring	180/55-17	Supermaxx Sport M6029 Supermaxx Touring
YB5	120/70-18	Supermaxx Sport M6029 Supermaxx Touring	160/60-18	Supermaxx Sport M6029 Supermaxx Touring
YB6	120/70-17	Supermaxx Sport M6029 Supermaxx Touring	180/55-17	Supermaxx Sport M6029 Supermaxx Touring
YB8	120/70-17	Supermaxx Sport M6029 Supermaxx Touring	180/55-17	Supermaxx Sport M6029 Supermaxx Touring
YB9 SR	120/70-17	Supermaxx Sport M6029 Supermaxx Touring	160/60-17	Supermaxx Sport M6029 Supermaxx Touring
YB11	120/70-17	Supermaxx Sport M6029 Supermaxx Touring	180/55-17	Supermaxx Sport M6029 Supermaxx Touring
BMW				
R45	90/90-18	C906 Hi-Max	4.00-18	
R50/5	3.25-19		120/90-18	C907 Hi-Max
R60/5	3.25-19		120/90-18	C907 Hi-Max
R60/6	3.25-19		4.00-18	
R60/7	3.25-19		4.00-18	
F650 E	100/90-19		130/80-17	M6017 Traxer
F650 CS (Belt)	110/70-17		160/60-17	
F650 GS	110/80-19		140/80-17	M6017 Traxer
F650 GS Dakar	90/90-21	M6017 Traxer	130/80-17	M6017 Traxer
F650 ST	100/90-18		130/80-17	M6017 Traxer
G650 X Country	100/90-19		130/80-17	M6017 Traxer
G650 X Moto	120/70-17		160/60-17	
R65 - 20/35 KW	90/90-18	C906 Hi-Max	120/90-18	C907 Hi-Max
R65 GS	3.00-21	C858 Premium Trail	4.60-18	
R65 LS	90/90-18	C906 Hi-Max	4.00-18	
K75 /C	100/90-18	C906 Hi-Max	120/90-18	C907 Hi-Max

Motorcycle Fitment Guide

Model	Front	Pattern	Rear	Pattern
BMW continued				
K75 RT/S	100/90-18	C906 Hi-Max	130/90-17	C907 Hi-Max
R75/5	3.25-19		120/90-18	C907 Hi-Max
R75/6	3.25-19		4.00-18	
R75/7	3.25-19		4.00-18	
F800 GS	90/90-21	M6017 Traxer	150/70-17	MA-D Detour
F800 R	120/70-17	Supermaxx Sport M6029 Supermaxx Touring	180/55-17	Supermaxx Sport M6029 Supermaxx Touring
F800 S/ST	120/70-17	Supermaxx Sport M6029 Supermaxx Touring	180/55-17	Supermaxx Sport M6029 Supermaxx Touring
R80	90/90-18	C906 Hi-Max	120/90-18	C907 Hi-Max
R80 GS	3.00-21		4.60-18	
R80 GS /Paris Dakar/Last Edition	90/90-21	M6017 Traxer	130/80-17	M6017 Traxer
R80 R Roadster	110/80-18		140/80-17	
R80 RT	3.25-19		4.00-18	
R80 RT	90/90-18	C906 Hi-Max	120/90-18	C907 Hi-Max
R80 ST	100/90-19	C906 Hi-Max	120/90-18	C907 Hi-Max
R80/7	3.25-19		4.00-18	
R850 C	100/90-18		170/80-15	M6011 Classic M6011 Whitewall
R850 R/RT	120/70-17	Supermaxx Sport M6029 Supermaxx Touring	160/60-18	
R850 R (Spoked Wheel)	110/80-18		150/70-17	M6029 Supermaxx Touring
R850 R/RT	120/70-17	Supermaxx Sport M6029 Supermaxx Touring	170/60-17	M6029 Supermaxx Touring
R90 S	3.25-19		4.00-18	
R90/6	3.25-19		4.00-18	
K1	120/70-17	Supermaxx Sport M6029 Supermaxx Touring	160/60-18	
K100	100/90-18	C906 Hi-Max	130/90-17	C907 Hi-Max
K100 LT	110/80-18		140/80-17	
K100 RS 2v	100/90-18	C906 Hi-Max	130/90-17	C907 Hi-Max
K100 RS 4v	120/70-17	Supermaxx Sport M6029 Supermaxx Touring	160/60-18	
K100 RT	100/90-18	C906 Hi-Max	130/90-17	C907 Hi-Max
K1100 LT	110/80-18		140/80-17	
K1100 RS	120/70-17	Supermaxx Sport M6029 Supermaxx Touring	160/60-18	
R100 CS	3.25-19		120/90-18	C907 Hi-Max
R100 GS	90/90-21	M6017 Traxer	130/80-17	M6017 Traxer
R100 R /Mystik	110/80-18		140/80-17	
R100 RS	3.25-19		120/90-18	C907 Hi-Max
R100 RS	90/90-18	C906 Hi-Max	120/90-18	C907 Hi-Max
R100 RT	3.25-19		120/90-18	C907 Hi-Max
R100 RT	90/90-18	C906 Hi-Max	120/90-18	C907 Hi-Max
S1000 RR	120/70-17	Supermaxx Sport M6029 Supermaxx Touring	180/55-17	Supermaxx Sport M6029 Supermaxx Touring
R1100 GS	110/80-19	MA-D Detour	150/70-17	MA-D Detour
R1100 R (Spoked Wheel)	110/80-18		150/70-17	M6029 Supermaxx Touring
R1100 R/RS/RT	120/70-17	Supermaxx Sport M6029 Supermaxx Touring	160/60-18	
R1100 S (5.00" Rim)	120/70-17	Supermaxx Sport M6029 Supermaxx Touring	170/60-17	M6029 Supermaxx Touring
R1100 S (5.50" Rim)	120/70-17	Supermaxx Sport M6029 Supermaxx Touring	180/55-17	Supermaxx Sport M6029 Supermaxx Touring
R1150 GS/Adventurer	110/80-19	MA-D Detour	150/70-17	MA-D Detour

Motorcycle Fitment Guide

Model	Front	Pattern	Rear	Pattern
BMW continued				
R1150 R	120/70-17	Supermaxx Sport M6029 Supermaxx Touring	170/60-17	M6029 Supermaxx Touring
R1150 R Rockster	120/70-17	Supermaxx Sport M6029 Supermaxx Touring	180/55-17	Supermaxx Sport M6029 Supermaxx Touring
R1150 RS/RT	120/70-17	Supermaxx Sport M6029 Supermaxx Touring	170/60-17	M6029 Supermaxx Touring
HP2 Megamoto	120/70-17	Supermaxx Sport M6029 Supermaxx Touring	180/55-17	Supermaxx Sport M6029 Supermaxx Touring
K1200 GT	120/70-17	Supermaxx Sport M6029 Supermaxx Touring	180/55-17	Supermaxx Sport M6029 Supermaxx Touring
K1200 LT	120/70-17	Supermaxx Sport M6029 Supermaxx Touring	160/70-17	Supermaxx Sport M6029 Supermaxx Touring
K1200 RS (5.00" Rim)	120/70-17	Supermaxx Sport M6029 Supermaxx Touring	170/60-17	M6029 Supermaxx Touring
K1200 RS (5.50" Rim)	120/70-17	Supermaxx Sport M6029 Supermaxx Touring	180/55-17	Supermaxx Sport M6029 Supermaxx Touring
R1200 C	100/90-18	C906 Hi-Max	170/80-15	M6011 Whitewall M6011 Classic
R1200 C Montauk	150/80-16	M6011 Whitewall	170/80-15	M6011 Whitewall M6011 Classic
R1200 CL	150/80-16	M6011 Whitewall	170/80-15	M6011 Whitewall M6011 Classic
R1200 GS	110/80-19	MA-D Detour	150/70-17	MA-D Detour
R1200 R/RT	120/70-17	Supermaxx Sport M6029 Supermaxx Touring	180/55-17	Supermaxx Sport M6029 Supermaxx Touring
R1200 S HP2	120/70-17	Supermaxx Sport M6029 Supermaxx Touring	190/55-17	Supermaxx Sport
R1200 S/ST	120/70-17	Supermaxx Sport M6029 Supermaxx Touring	180/55-17	Supermaxx Sport M6029 Supermaxx Touring
K1300 GT	120/70-17	Supermaxx Sport M6029 Supermaxx Touring	180/55-17	Supermaxx Sport M6029 Supermaxx Touring
K1300 R	120/70-17	Supermaxx Sport M6029 Supermaxx Touring	180/55-17	Supermaxx Sport M6029 Supermaxx Touring
K1300 S	120/70-17	Supermaxx Sport M6029 Supermaxx Touring	190/55-17	Supermaxx Sport
Buell				
XB9R Firebolt	120/70-17	M6029 Supermaxx Touring Supermaxx Sport	180/55-17	M6029 Supermaxx Touring Supermaxx Sport
XB9S Lightning	120/70-17	M6029 Supermaxx Touring Supermaxx Sport	180/55-17	M6029 Supermaxx Touring Supermaxx Sport
1125 R/CR	120/70-17	M6029 Supermaxx Touring Supermaxx Sport	180/55-17	M6029 Supermaxx Touring Supermaxx Sport
M2 Cyclone	120/70-17	M6029 Supermaxx Touring Supermaxx Sport	170/60-17	M6029 Supermaxx Touring
S1 Lightning	120/70-17	M6029 Supermaxx Touring Supermaxx Sport	170/60-17	M6029 Supermaxx Touring
S3 Thunderbold	120/70-17	M6029 Supermaxx Touring Supermaxx Sport	170/60-17	M6029 Supermaxx Touring
X1 Lightning	120/70-17	M6029 Supermaxx Touring Supermaxx Sport	170/60-17	M6029 Supermaxx Touring
XB12 R Firebolt	120/70-17	M6029 Supermaxx Touring Supermaxx Sport	180/55-17	M6029 Supermaxx Touring Supermaxx Sport
XB12 S Lightning	120/70-17	M6029 Supermaxx Touring Supermaxx Sport	180/55-17	M6029 Supermaxx Touring Supermaxx Sport
XB12 Ss Lightning Long	120/70-17	M6029 Supermaxx Touring Supermaxx Sport	180/55-17	M6029 Supermaxx Touring Supermaxx Sport

Motorcycle Fitment Guide

Model	Front	Pattern	Rear	Pattern
Buell continued				
XB12 X Ulysses	120/70-17	M6029 Supermaxx Touring Supermaxx Sport	180/55-17	M6029 Supermaxx Touring Supermaxx Sport
Cagiva				
Mito 125	120/70-17		150/60-17	
N1 125	120/70-17		150/60-17	
Planet 125	120/70-17		150/60-17	
Raptor 125	120/70-17		150/60-17	
SST250	90/90-18	C906 Hi-Max	4.00-18	
Alazzurra 350	90/90-18	C906 Hi-Max	120/80-18	C907 Hi-Max
SST350	90/90-18	C906 Hi-Max	4.00-18	
W12 350	90/90-21	M6017 Traxer	130/80-17	M6017 Traxer
Canyon 500	100/90-19		140/80-17	M6017 Traxer
River 600	110/80-17	M6029 Supermaxx Touring	150/70-17	M6029 Supermaxx Touring
W16 600	90/90-21	M6017 Traxer	130/80-17	M6017 Traxer
Alazzurra 650	90/90-18	C906 Hi-Max	120/80-18	C907 Hi-Max
650 Elefant	90/90-21	M6017 Traxer	130/80-17	M6017 Traxer
Raptor/V-Raptor 650	120/70-17	Supermaxx Sport M6029 Supermaxx Touring	160/60-17	Supermaxx Sport M6029 Supermaxx Touring
750 Elefant	100/90-19		140/80-17	M6017 Traxer
900 Elefant	100/90-19		140/80-17	M6017 Traxer
Gran Canyon 900ie	100/90-19		150/70-17	MA-D Detour
Navigator 1000	110/80-18		150/70-17	MA-D Detour
Raptor/V-Raptor/X-Raptor 1000	120/70-17	Supermaxx Sport M6029 Supermaxx Touring	180/55-17	Supermaxx Sport M6029 Supermaxx Touring
CCM				
404 Supermoto	120/70-17	M6118 Supermoto Supermaxx Sport M6029 Supermaxx Touring	150/60-17	
604 e Supermoto	120/60-17	Supermaxx Sport M6029 Supermaxx Touring	150/60-17	
604 r Roadster	120/60-17	Supermaxx Sport M6029 Supermaxx Touring	150/60-17	
R30 604	120/60-17	Supermaxx Sport M6029 Supermaxx Touring	150/60-17	
R35	120/70-17	M6118 Supermoto Supermaxx Sport M6029 Supermaxx Touring	150/70-17	M6029 Supermaxx Touring
640 r/rs Roadster	120/60-17	Supermaxx Sport M6029 Supermaxx Touring	150/60-17	
640 e Supermoto	120/60-17	Supermaxx Sport M6029 Supermaxx Touring	150/60-17	
644 Dual Sport Supermoto	120/70-17	M6118 Supermoto Supermaxx Sport M6029 Supermaxx Touring	150/60-17	
R30 644	120/60-17	Supermaxx Sport M6029 Supermaxx Touring	150/60-17	
Daelim				
Altino 125	2.75-18	C117 C-Rib	3.00-18	C180
VL125 Classic/Daystar	3.00-18	C-Rib C180	130/90-15	C907 Hi-Max
VS125 /Evolution	3.00-18	C-Rib C180	3.50-16	C155 C289
VT125 /Evolution	3.00-18	C-Rib C180	130/90-15	C907 Hi-Max

Motorcycle Fitment Guide

Model	Front	Pattern	Rear	Pattern
Ducati				
350 F3 Desmo R	100/90-16	C906 Hi-Max	120/80-18	C907 Hi-Max
400 SS Junior J	120/60-17	Supermaxx Sport M6029 Supermaxx Touring	160/60-17	Supermaxx Sport M6029 Supermaxx Touring
500 sl Pantah	100/90-18	C906 Hi-Max	110/90-18	C907 Hi-Max
600 SS/S	120/60-17	Supermaxx Sport M6029 Supermaxx Touring	160/60-17	Supermaxx Sport M6029 Supermaxx Touring
600 tl Pantah M600	100/90-18 120/60-17	C906 Hi-Max Supermaxx Sport M6029 Supermaxx Touring	110/90-18 160/60-17	C907 Hi-Max Supermaxx Sport M6029 Supermaxx Touring
620 S	120/70-17	Supermaxx Sport M6029 Supermaxx Touring	160/60-17	Supermaxx Sport M6029 Supermaxx Touring
M620	120/60-17	Supermaxx Sport M6029 Supermaxx Touring	160/60-17	Supermaxx Sport M6029 Supermaxx Touring
Multistrada 620	120/60-17	Supermaxx Sport M6029 Supermaxx Touring	160/60-17	Supermaxx Sport M6029 Supermaxx Touring
M695	120/60-17	Supermaxx Sport M6029 Supermaxx Touring	160/60-17	Supermaxx Sport M6029 Supermaxx Touring
M696	120/60-17	Supermaxx Sport M6029 Supermaxx Touring	160/60-17	Supermaxx Sport M6029 Supermaxx Touring
748 all models	120/70-17	Supermaxx Sport M6029 Supermaxx Touring	180/55-17	Supermaxx Sport M6029 Supermaxx Touring
749 /S/R	120/70-17	Supermaxx Sport M6029 Supermaxx Touring	190/50-17	Supermaxx Sport M6029 Supermaxx Touring
750 F1 R	120/80-16	C906 Hi-Max	130/80-18	C907 Hi-Max
750 SS	100/90-18		120/90-18	C907 Hi-Max
750 SS i.e.	120/70-17	Supermaxx Sport M6029 Supermaxx Touring	160/60-17	Supermaxx Sport M6029 Supermaxx Touring
750 SC/SS	120/60-17	Supermaxx Sport M6029 Supermaxx Touring	160/60-17	Supermaxx Sport M6029 Supermaxx Touring
M750	120/60-17	Supermaxx Sport M6029 Supermaxx Touring	160/60-17	Supermaxx Sport M6029 Supermaxx Touring
M800	120/60-17	Supermaxx Sport M6029 Supermaxx Touring	160/60-17	Supermaxx Sport M6029 Supermaxx Touring
800 S/SS	120/70-17	Supermaxx Sport M6029 Supermaxx Touring	180/55-17	Supermaxx Sport M6029 Supermaxx Touring
S2 R 800	120/70-17	Supermaxx Sport M6029 Supermaxx Touring	180/55-17	Supermaxx Sport M6029 Supermaxx Touring
848	120/70-17	Supermaxx Sport M6029 Supermaxx Touring	180/55-17	Supermaxx Sport M6029 Supermaxx Touring
851 Strada/SP	120/70-17	Supermaxx Sport M6029 Supermaxx Touring	180/55-17	Supermaxx Sport M6029 Supermaxx Touring
888 Strada/SP	120/70-17	Supermaxx Sport M6029 Supermaxx Touring	180/55-17	Supermaxx Sport M6029 Supermaxx Touring
900 Darmah	100/90-18	C906 Hi-Max	120/90-18	C907 Hi-Max
900 SD	100/90-18	C906 Hi-Max	120/90-18	C907 Hi-Max
900 SS i.e.	120/70-17	Supermaxx Sport M6029 Supermaxx Touring	180/55-17	Supermaxx Sport M6029 Supermaxx Touring
900 SS/SC2/3	120/70-17	Supermaxx Sport M6029 Supermaxx Touring	180/55-17	Supermaxx Sport M6029 Supermaxx Touring
M900 i.e./Monster	120/70-17	Supermaxx Sport M6029 Supermaxx Touring	180/55-17	Supermaxx Sport M6029 Supermaxx Touring
MH900 e	120/70-17	Supermaxx Sport M6029 Supermaxx Touring	180/55-17	Supermaxx Sport M6029 Supermaxx Touring
907 i.e. Paso	120/70-17	Supermaxx Sport M6029 Supermaxx Touring	180/55-17	Supermaxx Sport M6029 Supermaxx Touring

Motorcycle Fitment Guide

Model	Front	Pattern	Rear	Pattern
Ducati continued				
916 all models	120/70-17	Supermaxx Sport M6029 Supermaxx Touring	180/55-17	Supermaxx Sport M6029 Supermaxx Touring
Desmosedici RR	120/70-17	Supermaxx Sport M6029 Supermaxx Touring	200/55-16	
996	120/70-17	Supermaxx Sport M6029 Supermaxx Touring	190/50-17	Supermaxx Sport M6029 Supermaxx Touring
996 S/SPS	120/70-17	Supermaxx Sport M6029 Supermaxx Touring	180/55-17	Supermaxx Sport M6029 Supermaxx Touring
998 all models	120/70-17	Supermaxx Sport M6029 Supermaxx Touring	180/55-17	Supermaxx Sport M6029 Supermaxx Touring
999 all models	120/70-17	Supermaxx Sport M6029 Supermaxx Touring	190/50-17	Supermaxx Sport M6029 Supermaxx Touring
1000 Hailwood	100/90-18	C906 Hi-Max	120/90-18	C907 Hi-Max
Mille Replica	100/90-18	C906 Hi-Max	130/80-18	C907 Hi-Max
1000 SS	120/70-17	Supermaxx Sport M6029 Supermaxx Touring	180/55-17	Supermaxx Sport M6029 Supermaxx Touring
Hypermonster	120/70-17	Supermaxx Sport M6029 Supermaxx Touring	180/55-17	Supermaxx Sport M6029 Supermaxx Touring
GT1000	120/70-17	Supermaxx Sport M6029 Supermaxx Touring	180/55-17	Supermaxx Sport M6029 Supermaxx Touring
S2 R 1000	120/70-17	Supermaxx Sport M6029 Supermaxx Touring	180/55-17	Supermaxx Sport M6029 Supermaxx Touring
S4 R/RS	120/70-17	Supermaxx Sport M6029 Supermaxx Touring	180/55-17	Supermaxx Sport M6029 Supermaxx Touring
M1000	120/70-17	Supermaxx Sport M6029 Supermaxx Touring	180/55-17	Supermaxx Sport M6029 Supermaxx Touring
Multistrada 1000	120/70-17	Supermaxx Sport M6029 Supermaxx Touring	180/55-17	Supermaxx Sport M6029 Supermaxx Touring
Paul Smart 1000	120/70-17	Supermaxx Sport M6029 Supermaxx Touring	180/55-17	Supermaxx Sport M6029 Supermaxx Touring
Sport 1000 /Biposto	120/70-17	Supermaxx Sport M6029 Supermaxx Touring	180/55-17	Supermaxx Sport M6029 Supermaxx Touring
ST2	120/70-17	Supermaxx Sport M6029 Supermaxx Touring	180/55-17	Supermaxx Sport M6029 Supermaxx Touring
ST3 /S	120/70-17	Supermaxx Sport M6029 Supermaxx Touring	180/55-17	Supermaxx Sport M6029 Supermaxx Touring
ST4 /S	120/70-17	Supermaxx Sport M6029 Supermaxx Touring	180/55-17	Supermaxx Sport M6029 Supermaxx Touring
1098 /S/R	120/70-17	Supermaxx Sport M6029 Supermaxx Touring	190/55-17	Supermaxx Sport
Hypermotard	120/70-17	Supermaxx Sport M6029 Supermaxx Touring	180/55-17	Supermaxx Sport M6029 Supermaxx Touring
Monster 1100 /S	120/70-17	Supermaxx Sport M6029 Supermaxx Touring	180/55-17	Supermaxx Sport M6029 Supermaxx Touring
M1100	120/70-17	Supermaxx Sport M6029 Supermaxx Touring	180/55-17	Supermaxx Sport M6029 Supermaxx Touring
MTS1100 /S	120/70-17	Supermaxx Sport M6029 Supermaxx Touring	180/55-17	Supermaxx Sport M6029 Supermaxx Touring
Multistrada 1100	120/70-17	Supermaxx Sport M6029 Supermaxx Touring	180/55-17	Supermaxx Sport M6029 Supermaxx Touring
1198 /S/R	120/70-17	Supermaxx Sport M6029 Supermaxx Touring	190/55-17	Supermaxx Sport
Gilera				
Cougar 125	100/80-17		130/70-17	
DNA 50	120/70-15	M6128	140/70-14	M6112

Motorcycle Fitment Guide

Model	Front	Pattern	Rear	Pattern
Gilera continued				
XRT350	90/90-21	M6017 Traxer C6006 Dual Sport Trail	130/80-17	M6017 Traxer C6006 Dual Sport Trail
Dakota 500	90/90-21	M6017 Traxer C6006 Dual Sport Trail	130/80-17	M6017 Traxer C6006 Dual Sport Trail
500 Saturno	110/70-17	M6029 Supermaxx Touring	150/60-17	
600 Nordcape	120/70-17	Supermaxx Sport M6029 Supermaxx Touring	160/60-17	Supermaxx Sport M6029 Supermaxx Touring
600 Nordwest	120/60-17	Supermaxx Sport M6029 Supermaxx Touring	160/60-17	Supermaxx Sport M6029 Supermaxx Touring
RC600 /C	90/90-21	M6017 Traxer C6006 Dual Sport Trail	130/80-17	M6017 Traxer C6006 Dual Sport Trail
XRT600	90/90-21	M6017 Traxer	130/80-17	M6017 Traxer
Harley-Davidson				
Bad Boy FXSTSB	80/90-21	M6011 Classic	130/90-16	M6011 Classic M6011 Whitewall
Daytona Dyna Glide FXDB	80/90-21	M6011 Classic	130/90-16	M6011 Classic M6011 Whitewall
Disc Glide FXDG	80/90-21	M6011 Classic	130/90-16	M6011 Classic M6011 Whitewall
Dyna Convertible FXDS	100/90-19	M6011 Classic M6011 Whitewall	130/90-16	M6011 Classic M6011 Whitewall
Dyna Low Rider FXDL	100/90-19	M6011 Classic M6011 Whitewall	130/90-16	M6011 Classic M6011 Whitewall
Dyna Street Bob FXDB	100/90-19	M6011 Classic M6011 Whitewall	160/70-17	
Dyna Super Glide FXD	80/90-21	M6011 Classic	130/90-16	M6011 Classic M6011 Whitewall
Dyna Wide Glide FXDWG	80/90-21	M6011 Classic	130/90-16	M6011 Classic M6011 Whitewall
Electra Glide FLH	130/90-16	M6011 Classic M6011 Whitewall	130/90-16	M6011 Classic M6011 Whitewall
Electra Glide FLHT	130/90-16	M6011 Classic M6011 Whitewall	130/90-16	M6011 Classic M6011 Whitewall
Electra Glide FLTC	130/90-16	M6011 Classic M6011 Whitewall	130/90-16	M6011 Classic M6011 Whitewall
Electra Glide Classic FLHTC	130/90-16	M6011 Classic M6011 Whitewall	130/90-16	M6011 Classic M6011 Whitewall
Electra Glide Sport FLHS	130/90-16	M6011 Classic M6011 Whitewall	130/90-16	M6011 Classic M6011 Whitewall
Fat Boy FLSTF	130/90-16	M6011 Classic M6011 Whitewall	130/90-16	M6011 Classic M6011 Whitewall
Fat Boy FXSTF	80/90-21	M6011 Classic	130/90-16	M6011 Classic M6011 Whitewall
Fat Boy FXEF	100/90-19	M6011 Classic M6011 Whitewall	130/90-16	M6011 Classic M6011 Whitewall
Heritage Softail Classic FLST	130/90-16	M6011 Classic M6011 Whitewall	130/90-16	M6011 Classic M6011 Whitewall
Heritage Softail Custom FLSTC	130/90-16	M6011 Classic M6011 Whitewall	130/90-16	M6011 Classic M6011 Whitewall
Low Rider FXS	100/90-19	M6011 Classic M6011 Whitewall	130/90-16	M6011 Classic M6011 Whitewall
Low Rider FXSB	100/90-19	M6011 Classic M6011 Whitewall	130/90-16	M6011 Classic M6011 Whitewall
Low Rider Custom FXLR	80/90-21	M6011 Classic	130/90-16	M6011 Classic M6011 Whitewall

Motorcycle Fitment Guide

Model	Front	Pattern	Rear	Pattern
Harley-Davidson continued				
Roadster XLS1000	100/90-19	M6011 Classic M6011 Whitewall	130/90-16	M6011 Classic M6011 Whitewall
Roadster XLX1000	100/90-19	M6011 Classic M6011 Whitewall	130/90-16	M6011 Classic M6011 Whitewall
Roadster XR1200	100/90-19	M6011 Classic M6011 Whitewall	130/90-16	M6011 Classic M6011 Whitewall
Rocker C FXCWC	90/90-19	M6011 Classic	240/40-18	
Softail FXST	80/90-21	M6011 Classic	130/90-16	M6011 Classic M6011 Whitewall
Softail Cross Bones FLSTSB	130/90-16	M6011 Classic	200/55-17	
Softail Custom FXSTC	80/90-21	M6011 Classic	130/90-16	M6011 Classic M6011 Whitewall
Softail Heritage FXSTL	80/90-21	M6011 Classic	130/90-16	M6011 Classic M6011 Whitewall
Softail Springer FXSTS	80/90-21	M6011 Classic	130/90-16	M6011 Classic M6011 Whitewall
Sportster D.L. XLH883	100/90-19	M6011 Classic M6011 Whitewall	130/90-16	M6011 Classic M6011 Whitewall
Sportster Hugger XLH883	100/90-19	M6011 Classic M6011 Whitewall	130/90-16	M6011 Classic M6011 Whitewall
Sportster XL883/XL1200 R	100/90-19	M6011 Classic M6011 Whitewall	130/90-16	M6011 Classic M6011 Whitewall
Sportster XLH1000	100/90-19	M6011 Classic M6011 Whitewall	130/90-16	M6011 Classic M6011 Whitewall
Sportster XLH1100	100/90-19	M6011 Classic M6011 Whitewall	130/90-16	M6011 Classic M6011 Whitewall
Sportster XLH1200	100/90-19	M6011 Classic M6011 Whitewall	130/90-16	M6011 Classic M6011 Whitewall
Sturgis FXB	100/90-19	M6011 Classic M6011 Whitewall	130/90-16	M6011 Classic M6011 Whitewall
Tour Glide Classic FLTC	130/90-16	M6011 Classic M6011 Whitewall	130/90-16	M6011 Classic M6011 Whitewall
Tour Glide FLT	130/90-16	M6011 Classic M6011 Whitewall	130/90-16	M6011 Classic M6011 Whitewall
Ultra Classic Electra Glide FLHTU	130/90-16	M6011 Classic M6011 Whitewall	130/90-16	M6011 Classic M6011 Whitewall
Ultra Classic Tour Glide FLTU	130/90-16	M6011 Classic M6011 Whitewall	130/90-16	M6011 Classic M6011 Whitewall
Wide Glide FXWG	80/90-21	M6011 Classic	130/90-16	M6011 Classic M6011 Whitewall
XR1200	120/70-18		190/50-17	Supermaxx Sport M6029 Supermaxx Touring
Honda				
MB50	2.50-18	C113	2.75-18	C117
MBX50	2.50-18	C113	2.75-18	C117
NS1	90/80-17		100/80-17	
MB80	2.75-18	C117 C-Rib	2.75-18	C117
MBX80	2.75-18	C117 C-Rib	3.00-18	C180
S90	2.50-18	C113	2.50-18	C113
CB100	2.50-18	C113	2.75-18	C117
CA125 Rebel	3.00-18	C180 C-Rib	130/90-15	C907 Hi-Max
CB125	2.50-18	C113	2.25-17	C117

Motorcycle Fitment Guide

Model	Front	Pattern	Rear	Pattern
Honda continued				
CB125 K Disc	2.75-18	C117 C-Rib	3.00-18	C180
CB125 Rebel	3.00-18	C180 C-Rib	130/90-15	C907 Hi-Max
CBR125 R	100/80-17		120/80-17	
NSR125	100/80-17		130/70-17	
XL125 Varadero	100/90-18		130/80-17	
VT125 C Shadow	100/90-17		130/90-15	C907 Hi-Max
VT125	3.00-18	C180 C-Rib	130/90-15	C907 Hi-Max
CM185 T	3.00-17	C180 C-Rib	3.50-16	C155 C289
CB200 Disc	2.75-18	C180 C-Rib	3.00-18	C180
CM200 T	3.00-17	C180 C-Rib	3.50-16	C155 C289
CB250 RS	3.00-18	C180 C-Rib	4.10-18	
CJ250 T	3.00-18	C180 C-Rib	3.75-18	
CMX250	3.00-18	C180 C-Rib	130/90-15	C907 Hi-Max
NSR250	110/70-17	M6029 Supermaxx Touring	150/60-17	
CJ360 T	3.00-18	C180 C-Rib	3.75-18	
CB1 NC27	110/70-17	M6029 Supermaxx Touring	140/70-17	
CB400 Four	90/90-18	C906 Hi-Max	110/90-18	C907 Hi-Max
CBR400 RR NC29	120/60-17	Supermaxx Sport M6029 Supermaxx Touring	150/60-17	
CM400 T	100/90-18	C906 Hi-Max	110/90-16	
NS400 R	110/90-16		120/90-17	
RVF400 NC35	120/60-17	Supermaxx Sport M6029 Supermaxx Touring	150/60-17	
VFR400 NC24	100/90-16	C906 Hi-Max	130/70-18	
VFR400 R NC30	120/60-17	Supermaxx Sport M6029 Supermaxx Touring	150/60-18	
CB450 K1-5	3.50-18	C117	4.00-18	C180
CB450 N	3.25-19	C-Rib	120/80-18	C907 Hi-Max
CB450 S	100/90-18	C906 Hi-Max	110/90-18	C907 Hi-Max
CB500 /T	3.25-19	C-Rib	4.00-18	C180
CB500 /S	110/80-17	M6029 Supermaxx Touring	130/80-17	
CBF500	120/70-17	M6029 Supermaxx Touring Supermaxx Sport	160/60-17	M6029 Supermaxx Touring Supermaxx Sport
CX500	3.25-19	C-Rib	4.00-18	C180
CX500 C	100/90-19	M6011 Classic C906 Hi-Max	130/90-16	M6011 Classic C907 Hi-Max
CX500 Euro Sport	100/90-19	C906 Hi-Max	120/80-18	C907 Hi-Max
CX500 Turbo	100/90-19	C906 Hi-Max	120/90-17	
FT500	100/90-19	C906 Hi-Max	120/90-18	C907 Hi-Max
GB500 Clubman	90/90-18	C906 Hi-Max	110/90-18	C907 Hi-Max
GL500	100/90-19	C906 Hi-Max	130/90-16	C907 Hi-Max
VF500 F	100/90-16	C906 Hi-Max	110/90-18	C907 Hi-Max
VT500 C	100/90-18	M6011 Classic C906 Hi-Max	130/90-16	M6011 Classic C907 Hi-Max
VT500 E	100/90-18	C906 Hi-Max	120/80-18	C907 Hi-Max
XBR500 /S	100/90-18	C906 Hi-Max	110/90-18	C907 Hi-Max

Motorcycle Fitment Guide

Model	Front	Pattern	Rear	Pattern
Honda continued				
CB550	3.25-19	C-Rib	4.00-18	C180
CBX550 F/F2	90/90-18	C906 Hi-Max	110/80-18	
CB600 F Hornet	120/70-16		180/55-17	Supermaxx Sport M6029 Supermaxx Touring
CB600 F Hornet/S	120/70-17	Supermaxx Sport M6029 Supermaxx Touring	180/55-17	Supermaxx Sport M6029 Supermaxx Touring
CBF600	120/70-17	Supermaxx Sport M6029 Supermaxx Touring	160/60-17	Supermaxx Sport M6029 Supermaxx Touring
CBR600 F	110/80-17	M6029 Supermaxx Touring	140/80-17	
CBR600 F	120/60-17	Supermaxx Sport M6029 Supermaxx Touring	160/60-17	Supermaxx Sport M6029 Supermaxx Touring
CBR600 F	120/70-17	Supermaxx Sport M6029 Supermaxx Touring	180/55-17	Supermaxx Sport M6029 Supermaxx Touring
CBR600 RR all models inc. ABS	120/70-17	Supermaxx Sport M6029 Supermaxx Touring	180/55-17	Supermaxx Sport M6029 Supermaxx Touring
VT600 C	100/90-19	M6011 Classic M6011 Whitewall	170/80-15	M6011 Classic M6011 Whitewall
XL600 V/VT Transalp	90/90-21	M6017 Traxer	130/80-17	M6017 Traxer
XR600	90/90-21	M6017 Traxer	120/90-18	
CB650	3.25-19	C-Rib	4.00-18	C180
CB650 C/SC	100/90-19	M6011 Classic C906 Hi-Max	130/90-16	M6011 Classic C907 Hi-Max
CBX650 Euro Sport	100/90-19	M6011 Classic C906 Hi-Max	130/90-16	M6011 Classic C907 Hi-Max
CX650 C	100/90-19	M6011 Classic C906 Hi-Max	140/90-15	C907 Hi-Max
CX650 Euro Sport	100/90-19	M6011 Classic C906 Hi-Max	120/80-18	C907 Hi-Max
CX650 Turbo	100/90-19	M6011 Classic C906 Hi-Max	120/90-17	
FMX650	120/70-17	Supermaxx Sport M6029 Supermaxx Touring	150/60-17	
FX650 Vigor	100/90-19	C906 Hi-Max	120/90-17	
GL650 D	100/90-19	M6011 Classic C906 Hi-Max	130/90-16	M6011 Classic C907 Hi-Max
NT650 GT Hawk	110/70-17	M6029 Supermaxx Touring	160/60-17	M6029 Supermaxx Touring
NT650 V Deauville	120/70-17	M6029 Supermaxx Touring	150/70-17	M6029 Supermaxx Touring
NTV650 Revere	110/80-17	M6029 Supermaxx Touring	150/70-17	M6029 Supermaxx Touring
NX650 Dominator	90/90-21	M6017 Traxer C6006 Dual Sport Trail	120/90-17	
SLR650	100/90-19	C906 Hi-Max	120/90-17	
XL650V Transalp	90/90-21	M6017 Traxer	120/90-17	
XR650 L/R	90/90-21	M6017 Traxer	140/80-18	
XRV650 Africa Twin	90/90-21	M6017 Traxer	130/90-17	
DN-01	120/70-17	M6029 Supermaxx Touring Supermaxx Sport	190/50-17	M6029 Supermaxx Touring Supermaxx Sport
NT700 V Deauville	120/70-17	M6029 Supermaxx Touring Supermaxx Sport	150/70-17	M6029 Supermaxx Touring
XL700 V Transalp	100/90-19		130/80-17	
CB750 C	100/90-19	M6011 Classic M6011 Whitewall	130/90-16	M6011 Classic M6011 Whitewall
CB750 F/F2	100/90-19		120/90-18	C907 Hi-Max
CB750 KO-K6/F1/F2	3.25-19	C-Rib	4.00-18	C180
CB750 K7/KZ	100/90-19	C906	130/90-17	C907 Hi-Max
CB750 Nighthawk	110/80-19		140/70-17	

Motorcycle Fitment Guide

Model	Front	Pattern	Rear	Pattern
Honda continued				
CB Seven Fifty	120/70-17	M6029 Supermaxx Touring Supermaxx Sport	150/70-17	M6029 Supermaxx Touring
CBX750 F	110/90-16		130/80-18	C907 Hi-Max
CBX750 Pro Link	100/90-19	C906	130/80-18	C907 Hi-Max
NR750 RC40	130/70-16	M6029 Supermaxx Touring	180/55-17	M6029 Supermaxx Touring Supermaxx Sport
RVF750 R RC45	130/70-16	M6029 Supermaxx Touring	190/50-17	M6029 Supermaxx Touring Supermaxx Sport
VF750 C	110/90-18		130/90-16	M6011 Classic
VF750 F	120/80-16	C906 Hi-Max	130/80-18	C907 Hi-Max
VF750 S	110/90-18		130/90-17	C907 Hi-Max
VFR750 F	120/80-16	C906 Hi-Max	150/70-18	
VFR750 F	110/80-17	M6029 Supermaxx Touring	140/80-17	
VFR750 F/R	120/70-17	M6029 Supermaxx Touring Supermaxx Sport	170/60-17	M6029 Supermaxx Touring
VFR750 F	120/70-17	Supermaxx Sport M6029 Supermaxx Touring	180/55-17	Supermaxx Sport M6029 Supermaxx Touring
VT750 Black Widow	110/80-19		160/80-15	
VT750 C	100/90-19	M6011 Classic M6011 Whitewall	140/90-15	C907 Hi-Max M6011 Whitewall
VT750 C	120/90-17		160/80-15	
VT750 C2	120/90-17		170/80-15	M6011 Classic M6011 Whitewall
VT750 Shadow	120/90-17		160/80-15	
VT750 Shadow Spirit	90/90-21		160/80-15	
XLV750 R	90/90-21	M6017 Traxer	130/80-17	M6017 Traxer
XRV750 Africa Twin	90/90-21	M6017 Traxer	130/90-17	
XRV750 Africa Twin	90/90-21	M6017 Traxer	140/80-17	M6017 Traxer
VFR800	120/70-17	Supermaxx Sport M6029 Supermaxx Touring	180/55-17	Supermaxx Sport M6029 Supermaxx Touring
CB900 F Hornet	120/70-17	Supermaxx Sport M6029 Supermaxx Touring	180/55-17	Supermaxx Sport M6029 Supermaxx Touring
CB900 F	100/90-19	C906 Hi-Max	120/90-18	C907 Hi-Max
CB900 F/F2	100/90-18	C906 Hi-Max	130/80-18	C907 Hi-Max
CBR900 RR	130/70-16	M6029 Supermaxx Touring	180/55-17	M6029 Supermaxx Touring Supermaxx Sport
CBR900 RR	120/70-17	Supermaxx Sport M6029 Supermaxx Touring	190/50-17	Supermaxx Sport M6029 Supermaxx Touring
CB1000 F	120/70-18		170/60-18	
CB1000 R /ABS	120/70-17	Supermaxx Sport M6029 Supermaxx Touring	180/55-17	Supermaxx Sport M6029 Supermaxx Touring
CBF1000	120/70-17	Supermaxx Sport M6029 Supermaxx Touring	160/60-17	Supermaxx Sport M6029 Supermaxx Touring
CBR1000 F	110/70-17	M6029 Supermaxx Touring	150/70-17	M6029 Supermaxx Touring
CBR1000 F	120/70-17	Supermaxx Sport M6029 Supermaxx Touring	180/55-17	Supermaxx Sport M6029 Supermaxx Touring
CBR1000 RR Fireblade inc. ABS	120/70-17	Supermaxx Sport M6029 Supermaxx Touring	190/50-17	Supermaxx Sport M6029 Supermaxx Touring
CBX1000	100/90-19	C906 Hi-Max	120/90-18	C907 Hi-Max
CBX1000	100/90-19	C906 Hi-Max	130/80-18	C907 Hi-Max
GL1000	100/90-19	C906 Hi-Max	130/90-17	
VF1000 F/F2	120/80-16	C906 Hi-Max	140/80-17	
VF1000 F/F2	100/90-18	C906 Hi-Max	140/80-17	
VF1000 R	120/80-16	C906 Hi-Max	140/80-17	
VTR1000 Fire Storm	120/70-17	Supermaxx Sport M6029 Supermaxx Touring	180/55-17	Supermaxx Sport M6029 Supermaxx Touring

Motorcycle Fitment Guide

Model	Front	Pattern	Rear	Pattern
Honda continued				
VTR1000 SP-1/SP-2	120/70-17	Supermaxx Sport M6029 Supermaxx Touring	190/50-17	Supermaxx Sport M6029 Supermaxx Touring
XL1000 V Varadero	110/80-19	MA-D Detour	150/70-17	MA-D Detour
CB1100 F	100/90-18	C906 Hi-Max	130/90-17	C907 Hi-Max
CB1100 R	100/90-19	C906 Hi-Max	130/80-18	C907 Hi-Max
CB1100 R	100/90-18	C906 Hi-Max	130/80-18	C907 Hi-Max
CBR1100 XX	120/70-17	Supermaxx Sport M6029 Supermaxx Touring	180/55-17	Supermaxx Sport M6029 Supermaxx Touring
GL1100 DX	100/90-19	M6011 Classic M6011 Whitewall C906 Hi-Max	130/90-17	
ST1100 ABS+TCS	120/70-18		160/70-17	Supermaxx Sport M6029 Supermaxx Touring
ST1100 Pan European	110/80-18		160/70-17	Supermaxx Sport M6029 Supermaxx Touring
VF1100 C	110/90-18		150/80-16	C907 Hi-Max
VT1100 C3	140/80-17		170/80-15	M6011 Classic M6011 Whitewall
X-Eleven (CB1100 SF)	120/70-17	Supermaxx Sport M6029 Supermaxx Touring	180/55-17	Supermaxx Sport M6029 Supermaxx Touring
GL1200 DX	130/90-16	M6011 Classic M6011 Whitewall	150/90-15	M6011 Classic M6011 Whitewall
VFR1200 F	120/70-17	Supermaxx Sport M6029 Supermaxx Touring	190/55-17	Supermaxx Sport
CB1300	120/70-17	Supermaxx Sport M6029 Supermaxx Touring	190/60-17	
CB1300 inc. ABS	120/70-17	Supermaxx Sport M6029 Supermaxx Touring	180/55-17	Supermaxx Sport M6029 Supermaxx Touring
ST1300 ABS+TCS	120/70-18		170/60-17	M6029 Supermaxx Touring
VTX1300 C	140/80-19		170/80-15	M6011 Classic M6011 Whitewall
VTX1300 N	110/80-19		170/80-15	M6011 Classic M6011 Whitewall
VTX1300 S/T	140/80-17		170/80-15	M6011 Classic M6011 Whitewall
X4	120/70-18		190/60-17	
F6 C	150/80-17		180/70-16	
GL1500	130/70-18		160/80-16	
GL1800	130/70-18		180/60-16	
VTX1800	130/70-18		180/70-16	
Husqvarna				
SM125	120/70-17	M6118 Supermoto	150/60-17	
SM450	120/70-17	M6118 Supermoto	150/60-17	
SM510	120/70-17	M6118 Supermoto	150/60-17	
SM610	120/70-17	M6118 Supermoto	160/60-17	M61198 Supermoto
Hyosung				
GV125 Aquila	110/90-16		130/90-15	C907 Hi-Max
125 Comet	110/90-16		130/90-15	C907 Hi-Max
GT125 Comet	110/70-17		150/70-17	
RT125 Karion	130/80-18	C6006 Dual Sport Trail	180/80-14	
GV250 Aquila	110/90-16		150/80-15	M6011 Classic
GT250 Comet	110/70-17		150/70-17	
600 Comet	110/70-17	M6029 Supermaxx Touring	150/70-17	M6029 Supermaxx Touring
GT650 S Comet	120/60-17	M6029 Supermaxx Touring	160/60-17	M6029 Supermaxx Touring
GT650 R Comet	120/60-17	M6029 Supermaxx Touring	160/60-17	M6029 Supermaxx Touring
GV650 Aquila	120/60-18		180/55-17	Supermaxx Sport

Motorcycle Fitment Guide

Model	Front	Pattern	Rear	Pattern
Kawasaki				
AR50	2.50-18	C113	2.75-18	C117
AR80	2.50-18	C113	2.75-18	C117
BN125 Eliminator	3.00-17	C-Rib C180	130/90-15	C907 Hi-Max
KH125	2.75-18	C-Rib C117	3.00-18	C180
EL250 /E/EI	100/90-17		140/90-15	C907 Hi-Max
BJ250 A Estrella	90/90-18		110/90-17	
GPZ250	90/90-18		110/80-18	
KH250 B	90/90-18		4.00-18	C180
EX250 R Ninja	110/70-17		130/70-17	
Z250 C/LTD	2.75-18	C-Rib C117	120/90-16	C907 Hi-Max
Z250 LTD Belt Drive	3.00-19	C113	120/90-16	C907 Hi-Max
GPZ305	90/90-18	C906 Hi-Max	110/80-18	
GPZ400	3.25-19	C-Rib	4.00-18	C180
GPZ400	100/90-18	C906 Hi-Max	110/90-18	C907 Hi-Max
Z400 F/J	3.25-19	C-Rib	4.00-18	C180
Z400 G	90/90-18	C906 Hi-Max	4.00-18	C180
ZXR400	120/60-17	Supermaxx Sport M6029 Supermaxx Touring	160/60-17	Supermaxx Sport M6029 Supermaxx Touring
Z440 LTD	3.25-19	C-Rib	130/90-16	M6011 Classic M6011 Whitewall C907 Hi-Max
LTD450 Liquid cooled	100/90-19	M6011 Classic M6011 Whitewall C906 Hi-Max	140/90-15	M6011 Whitewall C907 Hi-Max
EN500 A/C	100/90-19	M6011 Classic M6011 Whitewall C906 Hi-Max	140/90-15	M6011 Whitewall C907 Hi-Max
ER5 A	110/70-17		130/70-17	
GPZ500 S	100/90-16	C906 Hi-Max	130/90-16	C907 Hi-Max
GPZ500 S	110/70-17	M6029 Supermaxx Touring	130/70-17	
KLE500	90/90-21	M6017 Traxer	130/80-17	M6017 Traxer
Z500B	3.25-19	C-Rib	4.00-18	C180
GPZ550	100/90-18	C906 Hi-Max	120/80-18	C907 Hi-Max
Z550 F/GP	3.25-19	C-Rib	4.00-18	C180
Z550 GT	100/90-19	C906 Hi-Max	120/90-18	C907 Hi-Max
Z550	3.25-19	C-Rib	3.75-18	
Z550 LTD	3.25-19	C-Rib	130/90-16	M6011 Classic M6011 Whitewall C907 Hi-Max
ZR550 B Zephyr	110/80-17	M6029 Supermaxx Touring	140/70-18	
GPZ600 R	120/80-16	C906 Hi-Max	150/80-16	
GPX600	120/80-16	C906 Hi-Max	150/80-16	
KLR600 E	90/90-21	M6017 Traxer	130/80-17	M6017 Traxer
KLR600	3.00-21		5.10-17	
ZL600 Eliminator	100/90-18	C906 Hi-Max	150/80-15	M6011 Classic
ZX-6R Ninja	120/70-17	Supermaxx Sport M6029 Supermaxx Touring	180/55-17	Supermaxx Sport M6029 Supermaxx Touring
ZX-6R F	120/60-17	Supermaxx Sport M6029 Supermaxx Touring	160/60-17	Supermaxx Sport M6029 Supermaxx Touring
ZX-6R G/H	120/60-17	M6029 Supermaxx Touring Supermaxx Sport	170/60-17	M6029 Supermaxx Touring
ZX-6R J	120/65-17	M6029 Supermaxx Touring	180/55-17	Supermaxx Sport M6029 Supermaxx Touring

Motorcycle Fitment Guide

Model	Front	Pattern	Rear	Pattern
Kawasaki continued				
ZX-6R P	120/70-17	Supermaxx Sport M6029 Supermaxx Touring	180/55-17	Supermaxx Sport M6029 Supermaxx Touring
ZX-6R (636) A/B	120/70-17	Supermaxx Sport M6029 Supermaxx Touring	180/55-17	Supermaxx Sport M6029 Supermaxx Touring
ZX-6R (636) C	120/65-17	M6029 Supermaxx Touring	180/55-17	Supermaxx Sport M6029 Supermaxx Touring
ZX-6R 09>	120/70-17	Supermaxx Sport M6029 Supermaxx Touring	180/55-17	Supermaxx Sport M6029 Supermaxx Touring
ZX-6RR K	120/70-17	Supermaxx Sport M6029 Supermaxx Touring	180/55-17	Supermaxx Sport M6029 Supermaxx Touring
ZX-6RR N	120/65-17	M6029 Supermaxx Touring	180/55-17	Supermaxx Sport M6029 Supermaxx Touring
ZZR 600 D/E	120/60-17	Supermaxx Sport M6029 Supermaxx Touring	160/60-17	Supermaxx Sport M6029 Supermaxx Touring
ER-6F	120/70-17	Supermaxx Sport M6029 Supermaxx Touring	160/60-17	Supermaxx Sport M6029 Supermaxx Touring
ER-6N	120/70-17	Supermaxx Sport M6029 Supermaxx Touring	160/60-17	Supermaxx Sport M6029 Supermaxx Touring
KLR650 C	90/90-21	M6017 Traxer	120/90-17	
KLR650 Tengai	90/90-21	M6017 Traxer	130/80-17	M6017 Traxer
KLX650 C	90/90-21	M6017 Traxer	130/80-17	M6017 Traxer
Versys 650	120/70-17	Supermaxx Sport M6029 Supermaxx Touring	160/60-17	Supermaxx Sport M6029 Supermaxx Touring
W650	100/90-19	C906 Hi-Max	130/80-18	C907 Hi-Max
Z650 C	3.25-19	C-Rib	4.00-18	C180
Z650 F	3.25-19	C-Rib	4.00-18	C180
Z650	3.25-19	C-Rib	4.00-18	C180
Z650 SR	100/90-19	M6011 Classic M6011 Whitewall C906 Hi-Max	130/90-16	M6011 Classic M6011 Whitewall C907 Hi-Max
GPX750 R	120/80-16	C906 Hi-Max	150/70-18	
GPZ750	110/90-18		130/80-18	C907 Hi-Max
GPZ750 R	120/80-16	C906 Hi-Max	130/80-18	C907 Hi-Max
GPZ750 Turbo	110/90-18		130/80-18	C907 Hi-Max
VN750 Vulcan	100/90-19	M6011 Classic	150/90-15	M6011 Classic M6011 Whitewall
Z750 /S /ABS	120/70-17	Supermaxx Sport M6029 Supermaxx Touring	180/55-17	Supermaxx Sport M6029 Supermaxx Touring
Z750 /B	3.25-19	C-Rib	4.00-18	C180
Z750 GP/GT/Sport	100/90-19	C906 Hi-Max	120/90-18	C907 Hi-Max
Z750 LTD	3.25-19	C-Rib	130/90-16	M6011 Classic M6011 Whitewall C907 Hi-Max
Zephyr 750	120/70-17	Supermaxx Sport M6029 Supermaxx Touring	150/70-17	Supermaxx Sport M6029 Supermaxx Touring
ZR-7 /S	120/70-17	Supermaxx Sport M6029 Supermaxx Touring	160/60-17	Supermaxx Sport M6029 Supermaxx Touring
ZX-7R/RR	120/70-17	Supermaxx Sport M6029 Supermaxx Touring	190/50-17	Supermaxx Sport M6029 Supermaxx Touring
ZXR750 /R	120/70-17	Supermaxx Sport M6029 Supermaxx Touring	180/55-17	Supermaxx Sport M6029 Supermaxx Touring
VN800 Classic/Drifter	130/90-16	M6011 Classic M6011 Whitewall	140/90-16	M6011 Classic M6011 Whitewall
VN800	80/90-21	M6011 Classic	140/90-16	M6011 Classic M6011 Whitewall

Motorcycle Fitment Guide

Model	Front	Pattern	Rear	Pattern
Kawasaki continued				
GPZ900 R	120/70-17	Supermaxx Sport M6029 Supermaxx Touring	150/70-18	
GPZ900 R	120/80-16	C906 Hi-Max	130/80-18	C907 Hi-Max
VN900 Classic	130/90-16	M6011 Classic M6011 Whitewall	180/70-15	
Z1 R	100/90-18	C906 Hi-Max	120/90-18	C907 Hi-Max
Z900 Z1 F	3.25-19	C-Rib	4.00-18	C180
ZX-9R B/C/D	120/70-17	Supermaxx Sport M6029 Supermaxx Touring	180/55-17	Supermaxx Sport M6029 Supermaxx Touring
ZX-9R E/F	120/70-17	Supermaxx Sport M6029 Supermaxx Touring	190/50-17	Supermaxx Sport M6029 Supermaxx Touring
GPZ1000 RX	120/80-16	C906 Hi-Max	150/80-16	C907 Hi-Max
GTR1000	110/80-18		150/80-16	C907 Hi-Max
KLV1000	110/80-19	MA-D Detour	150/70-17	MA-D Detour
ZX-10R Ninja	120/70-17	Supermaxx Sport	190/55-17	Supermaxx Sport
Z1000 EFI/J/MkII/R	100/90-19	C906 Hi-Max	120/90-18	C907 Hi-Max
Z1000 ST	100/90-19	C906 Hi-Max	130/90-17	
Z1000 LTD	100/90-19	M6011 Classic C906 Hi-Max	130/90-16	
Z1000 Z1	3.25-19	C-Rib	4.00-18	C180
Z1000 /ABS	120/70-17	Supermaxx Sport M6029 Supermaxx Touring	190/50-17	Supermaxx Sport M6029 Supermaxx Touring
ZX-10R C	120/70-17	Supermaxx Sport M6029 Supermaxx Touring	190/50-17	Supermaxx Sport M6029 Supermaxx Touring
ZX-10R D/E	120/70-17	Supermaxx Sport M6029 Supermaxx Touring	190/55-17	Supermaxx Sport
ZX-10 B	120/70-17	Supermaxx Sport M6029 Supermaxx Touring	160/60-18	
GPZ1100	110/90-18		130/90-17	C907 Hi-Max
GPZ1100	120/70-17	M6029 Supermaxx Touring	170/60-17	M6029 Supermaxx Touring
Z1100 GP	100/90-19	C906 Hi-Max	120/90-18	C907 Hi-Max
Z1100 ST	100/90-19	M6011 Classic C906 Hi-Max	130/90-16	M6011 Classic M6011 Whitewall C907 Hi-Max
Zephyr 1100	120/70-18		160/70-17	Supermaxx Sport M6029 Supermaxx Touring
ZRX1100 C	120/70-17	Supermaxx Sport M6029 Supermaxx Touring	170/60-17	M6029 Supermaxx Touring
ZZR1100 C/D	120/70-17	Supermaxx Sport M6029 Supermaxx Touring	180/55-17	Supermaxx Sport M6029 Supermaxx Touring
ZRX1200 /R	120/70-17	Supermaxx Sport M6029 Supermaxx Touring	180/55-17	Supermaxx Sport M6029 Supermaxx Touring
ZX-12R	120/70-17	Supermaxx Sport M6029 Supermaxx Touring	200/50-17	M6029 Supermaxx Touring
ZZR1200 C	120/70-17	Supermaxx Sport M6029 Supermaxx Touring	180/55-17	Supermaxx Sport M6029 Supermaxx Touring
Z1300	110/90-18		130/90-17	C907 Hi-Max
GTR1400	120/70-17	Supermaxx Sport M6029 Supermaxx Touring	190/50-17	Supermaxx Sport M6029 Supermaxx Touring
ZZR1400	120/70-17	Supermaxx Sport M6029 Supermaxx Touring	190/50-17	Supermaxx Sport M6029 Supermaxx Touring
VN1500 /SE	100/90-19	M6011 Classic M6011 Whitewall	150/90-15	M6011 Classic M6011 Whitewall
VN1500 Classic/Drifter	130/90-16	M6011 Classic M6011 Whitewall	150/80-16	M6011 Classic
VN1500 Classic Tourer	150/80-16	M6011 Whitewall	150/80-16	M6011 Classic

Motorcycle Fitment Guide

Model	Front	Pattern	Rear	Pattern
Kawasaki continued				
VN1500 Mean Streak	130/70-17		170/60-17	M6029 Supermaxx Touring
VN1600 A	130/90-16	M6011 Classic M6011 Whitewall	170/70-16	
VN1600 Classic Tourer	150/80-16	M6011 Whitewall	170/70-16	
VN1600 Mean Streak	130/70-17		170/60-17	
VN1700 Classic	130/90-16	M6011 Classic M6011 Whitewall	170/70-16	
VN2000 A/Classic	150/80-16	M6011 Whitewall	200/60-16	
KTM				
Sting 125	110/70-17		130/70-17	
Duke 620	120/70-17	Supermaxx Sport M6029 Supermaxx Touring	160/60-17	Supermaxx Sport M6029 Supermaxx Touring
Duke II	120/70-17	Supermaxx Sport M6029 Supermaxx Touring	160/60-17	Supermaxx Sport M6029 Supermaxx Touring
640 LC4 Supermoto	120/70-17	M6118 Supermoto	160/60-17	M6119 Supermoto
660 SMC	120/70-17	M6118 Supermoto	160/60-17	M6119 Supermoto
690 Duke LC4	120/70-17	Supermaxx Sport M6029 Supermaxx Touring	160/60-17	Supermaxx Sport M6029 Supermaxx Touring
690 SM - R	120/70-17	Supermaxx Sport M6029 Supermaxx Touring M6118 Supermoto	160/60-17	Supermaxx Sport M6029 Supermaxx Touring M6119 Supermoto
690 SMC LC4	120/70-17	Supermaxx Sport M6029 Supermaxx Touring M6118 Supermoto	160/60-17	Supermaxx Sport M6029 Supermaxx Touring M6119 Supermoto
690 Supermoto LC4	120/70-17	Supermaxx Sport M6029 Supermaxx Touring M6118 Supermoto	160/60-17	Supermaxx Sport M6029 Supermaxx Touring M6119 Supermoto
950 Supermoto LC8 SM	120/70-17	Supermaxx Sport M6029 Supermaxx Touring M6118 Supermoto	180/55-17	Supermaxx Sport M6029 Supermaxx Touring
950 Supermoto R LC8 SM	120/70-17	Supermaxx Sport M6029 Supermaxx Touring M6118 Supermoto	180/55-17	Supermaxx Sport M6029 Supermaxx Touring
990 SM	120/70-17	Supermaxx Sport M6029 Supermaxx Touring M6118 Supermoto	180/55-17	Supermaxx Sport M6029 Supermaxx Touring
990 SM - R/T	120/70-17	Supermaxx Sport M6029 Supermaxx Touring M6118 Supermoto	180/55-17	Supermaxx Sport M6029 Supermaxx Touring
990 Superduke	120/70-17	Supermaxx Sport M6029 Supermaxx Touring	180/55-17	Supermaxx Sport M6029 Supermaxx Touring
990 Superduke LC8	120/70-17	Supermaxx Sport M6029 Supermaxx Touring	180/55-17	Supermaxx Sport M6029 Supermaxx Touring
990 Superduke R	120/70-17	Supermaxx Sport M6029 Supermaxx Touring	180/55-17	Supermaxx Sport M6029 Supermaxx Touring
990 Superduke R LC8	120/70-17	Supermaxx Sport M6029 Supermaxx Touring	180/55-17	Supermaxx Sport M6029 Supermaxx Touring
990 Supermoto LC8 SM	120/70-17	Supermaxx Sport M6029 Supermaxx Touring	180/55-17	Supermaxx Sport M6029 Supermaxx Touring
1190 RC8 /R	120/70-17	Supermaxx Sport	190/55-17	Supermaxx Sport
Kymco				
Hipster 125 4V	3.00-18	C-Rib C180	130/90-15	C907 Hi-Max
Laverda				
500 SFC	100/90-18	C906 Hi-Max	110/90-18	C907 Hi-Max

Motorcycle Fitment Guide

Model	Front	Pattern	Rear	Pattern
Laverda continued				
650 Sport/Formula	120/60-17	Supermaxx Sport M6029 Supermaxx Touring	160/60-17	Supermaxx Sport M6029 Supermaxx Touring
668 Ghost/Strike	120/60-17	Supermaxx Sport M6029 Supermaxx Touring	160/60-17	Supermaxx Sport M6029 Supermaxx Touring
750 S Formula	120/60-17	Supermaxx Sport M6029 Supermaxx Touring	160/60-17	Supermaxx Sport M6029 Supermaxx Touring
750 SF 1-3	100/90-18	C906 Hi-Max	110/90-18	C907 Hi-Max
Strike 750	120/60-17	Supermaxx Sport	160/60-17	Supermaxx Sport
1000 Jota/RGS	100/90-18	C906 Hi-Max	120/90-18	C907 Hi-Max
Morini				
3½ Classic	100/90-18	C906 Hi-Max	4.00-18	C180
3½ Sport	90/90-18	C906 Hi-Max	4.00-18	C180
350 K2	100/90-18	C906 Hi-Max	4.00-18	C180
350 RLX Excalibur	100/90-18	C906 Hi-Max	130/90-16	C907 Hi-Max
400 Dart	110/90-16		130/70-17	
500 Maestro	100/90-18	C906 Hi-Max	4.00-18	
500 T/S	100/90-18	C906 Hi-Max	4.00-18	
500 V-Classic	100/90-18	C906 Hi-Max	4.00-18	
501 RLX Excalibur	100/90-18	C906 Hi-Max	130/90-16	C907 Hi-Max
9½	120/70-17	Supermaxx Sport M6029 Supermaxx Touring	180/55-17	Supermaxx Sport M6029 Supermaxx Touring
1200 Corsaro	120/70-17	Supermaxx Sport M6029 Supermaxx Touring	180/55-17	Supermaxx Sport M6029 Supermaxx Touring
Moto Guzzi				
V50 C	100/80-18		130/90-16	C907 Hi-Max
V65 Florida	100/90-18	C906 Hi-Max	130/90-16	C907 Hi-Max
V65 Lario	100/90-18	C906 Hi-Max	120/90-16	C907 Hi-Max
V65 /SP	100/90-18	C906 Hi-Max	110/90-18	C907 Hi-Max
Breva 750 Touring	110/70-17	M6029 Supermaxx Touring	130/80-17	
Nevada 750 /Classic/Touring	100/90-18	C906 Hi-Max	130/90-16	C907 Hi-Max
V7	4.00-18	C180	4.00-18	C180
V7 Classic	110/70-17	M6029 Supermaxx Touring	130/80-17	
V750 Breva i.e.	110/70-17	M6029 Supermaxx Touring	130/80-17	
850 Le Mans I/II/III	100/90-18	C906 Hi-Max	120/90-18	C907 Hi-Max
850 T3 /California	100/90-18	C906 Hi-Max	120/90-18	C907 Hi-Max
850 T4	100/90-18	C906 Hi-Max	120/90-18	C907 Hi-Max
850 T5	100/90-16	C906 Hi-Max	130/90-16	C907 Hi-Max
Breva 850	120/70-17	Supermaxx Sport M6029 Supermaxx Touring	180/55-17	Supermaxx Sport M6029 Supermaxx Touring
Griso 850	120/70-17	Supermaxx Sport M6029 Supermaxx Touring	180/55-17	Supermaxx Sport M6029 Supermaxx Touring
Norge 850	120/70-17	Supermaxx Sport M6029 Supermaxx Touring	180/55-17	Supermaxx Sport M6029 Supermaxx Touring
Bellagio	120/70-17	Supermaxx Sport M6029 Supermaxx Touring	180/55-17	Supermaxx Sport M6029 Supermaxx Touring
1000 California II/III/C Injection	110/90-18		120/90-18	C907 Hi-Max
1000 G5	100/90-18	M6029 Supermaxx Touring	110/90-18	C907 Hi-Max
1000 Le Mans	100/90-18	M6029 Supermaxx Touring	120/90-18	C907 Hi-Max
1000 S	100/90-18	M6029 Supermaxx Touring	120/90-18	C907 Hi-Max
1000 SP	100/90-18	M6029 Supermaxx Touring	110/90-18	C907 Hi-Max
Daytona	120/70-17	Supermaxx Sport M6029 Supermaxx Touring	160/60-18	
Daytona RS Injection	120/70-17	Supermaxx Sport M6029 Supermaxx Touring	160/60-17	Supermaxx Sport M6029 Supermaxx Touring
Le Mans IV	120/80-16		130/80-18	C907 Hi-Max
Le Mans V	100/90-18	M6029 Supermaxx Touring	120/90-18	C907 Hi-Max

Motorcycle Fitment Guide

Model	Front	Pattern	Rear	Pattern
Moto Guzzi continued				
Mille GT	100/90-18	M6029 Supermaxx Touring	120/90-18	C907 Hi-Max
V10 Centauro	120/70-17	Supermaxx Sport M6029 Supermaxx Touring	160/60-17	Supermaxx Sport M6029 Supermaxx Touring
1100 Sport Injection	120/70-17	Supermaxx Sport M6029 Supermaxx Touring	160/60-17	Supermaxx Sport M6029 Supermaxx Touring
1100 Sport Carburetor	120/70-17	Supermaxx Sport M6029 Supermaxx Touring	160/60-18	
Breva 1100	120/70-17	Supermaxx Sport M6029 Supermaxx Touring	180/55-17	Supermaxx Sport M6029 Supermaxx Touring
California 1100	110/90-18		140/80-17	
California 1100 Carburetor	110/90-18		140/80-17	
California Aluminium	110/90-18		140/80-17	
California Classic	110/90-18		150/70-17	M6029 Supermaxx Touring
California EV Touring	110/90-18		150/70-17	M6029 Supermaxx Touring
California EV80	110/90-18		150/70-17	M6029 Supermaxx Touring
California Touring	110/90-18		150/70-17	M6029 Supermaxx Touring
Griso 1100	120/70-17	Supermaxx Sport M6029 Supermaxx Touring	180/55-17	Supermaxx Sport M6029 Supermaxx Touring
Quota 1100 /E.S.	90/90-21	M6017 Traxer	130/80-17	M6017 Traxer
V11 /Sport/Le Mans	120/70-17	Supermaxx Sport M6029 Supermaxx Touring	180/55-17	Supermaxx Sport M6029 Supermaxx Touring
V11 Sport	120/70-17	Supermaxx Sport M6029 Supermaxx Touring	160/60-17	Supermaxx Sport M6029 Supermaxx Touring
1200 Sport	120/70-17	Supermaxx Sport M6029 Supermaxx Touring	180/55-17	Supermaxx Sport M6029 Supermaxx Touring
Breva 1200	120/70-17	Supermaxx Sport M6029 Supermaxx Touring	180/55-17	Supermaxx Sport M6029 Supermaxx Touring
Griso 1200 8V	120/70-17	Supermaxx Sport M6029 Supermaxx Touring	180/55-17	Supermaxx Sport M6029 Supermaxx Touring
Norge 1200	120/70-17	Supermaxx Sport M6029 Supermaxx Touring	180/55-17	Supermaxx Sport M6029 Supermaxx Touring
Stelvio 1200	110/80-19	MA-D Detour C6006 Dual Sport Trail	180/55-17	MA-D Detour C6006 Dual Sport Trail
MGS-01 Corsa	120/70-17	Supermaxx Sport M6029 Supermaxx Touring	180/55-17	Supermaxx Sport M6029 Supermaxx Touring
MV Agusta				
F4 750 all models	120/65-17	M6029 Supermaxx Touring	190/50-17	Supermaxx Sport M6029 Supermaxx Touring
F4 Brutale 910 all models	120/70-17	Supermaxx Sport M6029 Supermaxx Touring	190/50-17	Supermaxx Sport M6029 Supermaxx Touring
F4 Brutale 990 R	120/70-17	Supermaxx Sport M6029 Supermaxx Touring	190/55-17	Supermaxx Sport
F4 1000 all models	120/70-17	Supermaxx Sport M6029 Supermaxx Touring	190/50-17	Supermaxx Sport M6029 Supermaxx Touring
F4 1078 all models	120/70-17	Supermaxx Sport M6029 Supermaxx Touring	190/55-17	Supermaxx Sport
F4 Brutale 1078 all models	120/70-17	Supermaxx Sport M6029 Supermaxx Touring	190/55-17	Supermaxx Sport
F4 Brutale 1090 RR	120/70-17	Supermaxx Sport M6029 Supermaxx Touring	190/55-17	Supermaxx Sport
MZ/MuZ				
RT125	110/70-17		130/70-17	
Saxon Roadstar 125	2.75-18	C-Rib C117	3.50-16	C155 C289
125 SM	110/70-17		130/70-17	

Motorcycle Fitment Guide

Model	Front	Pattern	Rear	Pattern
MZ/MuZ continued				
TS125/150	2.75-18	C-Rib C117	3.00-18	C180
ES250	3.50-16	C155 C289	3.50-16	C155 C289
TS250/1	2.75-18	C-Rib C117	3.50-16	C155 C289
ETZ251	2.75-18	C-Rib C117	3.50-16	C155 C289
Saxon Country 500	90/100-17		120/90-16	
Baghira 660 E DE-3	90/90-21	M6017 Traxer C6006 Dual Sport Trail	120/80-18	C6006 Dual Sport Trail
Baghira Street Moto 660	120/70-17	Supermaxx Sport M6029 Supermaxx Touring M6118 Supermoto	160/60-17	Supermaxx Sport M6029 Supermaxx Touring M6119 Supermoto
Black Panther 660	120/70-17	Supermaxx Sport M6029 Supermaxx Touring	160/60-17	Supermaxx Sport M6029 Supermaxx Touring
Funbike Mastiff 660	120/60-17	M6118 Supermoto Supermaxx Sport M6029 Supermaxx Touring	150/60-17	M6119 Supermoto
Skorpion Fighter 660	110/70-17	M6029 Supermaxx Touring	150/60-17	
Skorpion Sport Cup 660	110/70-17	M6029 Supermaxx Touring	150/60-17	
Skorpion Sport 660	110/70-17	M6029 Supermaxx Touring	150/60-17	
Skorpion Tour 660	110/70-17	M6029 Supermaxx Touring	140/70-17	
Skorpion Traveller 660	110/70-17	M6029 Supermaxx Touring	150/60-17	
1000 S/SF	120/70-17	Supermaxx Sport M6029 Supermaxx Touring	180/55-17	Supermaxx Sport M6029 Supermaxx Touring
Norton				
Commander	100/90-18	C906 Hi-Max	120/90-18	C907 Hi-Max
F1	120/70-17	Supermaxx Sport M6029 Supermaxx Touring	180/55-17	Supermaxx Sport M6029 Supermaxx Touring
NRV588				
Commando 961 SE	120/70-17	Supermaxx Sport M6029 Supermaxx Touring	180/55-17	Supermaxx Sport M6029 Supermaxx Touring
Commando 961 Sport	120/70-17	Supermaxx Sport M6029 Supermaxx Touring	180/55-17	Supermaxx Sport M6029 Supermaxx Touring
Commando 961 Café Racer	120/70-17	Supermaxx Sport M6029 Supermaxx Touring	180/55-17	Supermaxx Sport M6029 Supermaxx Touring
Sachs				
X-Road 125	120/70-17		160/60-17	
XTC125 /N/Racing	110/70-17		150/60-17	
Roadster 650	120/70-17	Supermaxx Sport M6029 Supermaxx Touring	160/60-17	Supermaxx Sport M6029 Supermaxx Touring
660	110/70-17	M6029 Supermaxx Touring	150/60-17	
Roadster 800	120/70-17	Supermaxx Sport M6029 Supermaxx Touring	160/70-17	
Suzuki				
GT50 K	2.50-18	C113	2.50-18	C113
X-1 ZR50 K	2.50-18	C113	3.00-18	C180
RG80 Gamma	80/100-16		90/90-18	C907 Hi-Max
X-3 GT80 (A)	2.75-18	C-Rib C117	3.00-18	C180
DR125 SM	100/80-17		130/70-17	
GN125 /U	2.75-18	C-Rib C117	3.50-16	C155 C289
GP125	2.75-18	C-Rib C117	3.00-18	C180

Motorcycle Fitment Guide

Model	Front	Pattern	Rear	Pattern
Suzuki continued				
GS125	2.75-18	C-Rib C117	3.00-18	C180
GT125	2.75-18	C-Rib C117	3.00-18	C180
GZ125 Marauder	110/90-16	C906 Hi-Max	130/90-15	C907 Hi-Max
RG125	100/80-17		120/80-17	
TS125 ER	2.75-21	C858 Premium Trail	4.10-18	C868 Premium Trail
TU125 XT	2.75-18	C-Rib C117	3.50-16	C155 C289
VanVan 125	130/80-18		180/80-14	
VL125 Intruder	90/90-18	C906 Hi-Max	130/90-15	C907 Hi-Max
GT185	2.75-18	C-Rib C117	3.00-18	C180
X-5 GT200	2.75-18	C-Rib C117	3.00-18	C180
GN250	3.00-18	C-Rib C180	120/90-16	C907 Hi-Max
GSX250 E/X/XU	90/90-18	C906 Hi-Max	110/90-18	C907 Hi-Max
X-7 GT250	3.00-18	C-Rib C180	4.10-18	
GZ250 Marauder	110/90-16		130/90-15	C907 Hi-Max
RG250	110/90-16		110/80-18	C907 Hi-Max
RGV250 Gamma	110/70-17		150/60-17	
GT380	3.25-19	C-Rib	4.00-18	C180
DR-Z 400 SM Supermoto	120/70-17	M6118 Supermoto	150/60-17	
GN400 L/TD	3.60-18		4.60-16	C289
GSF400 Bandit	110/70-17	M6029 Supermaxx Touring	150/70-17	
GSX400	3.00-18	C-Rib C180	4.00-18	C180
GSX400 E/ES	90/90-18	C906 Hi-Max	110/90-18	C907 Hi-Max
GSX400 F Katana	3.25-19	C-Rib	110/90-18	C907 Hi-Max
GSX-R400	120/60-17	Spuremaxx Sport M6029 Supermaxx Touring	160/60-17	Spuremaxx Sport M6029 Supermaxx Touring
GS450 /E/S/SEU/SU	3.00-18	C-Rib C180	4.00-18	C180
GS450 L	3.25-19	C-Rib	120/90-16	C907 Hi-Max
GS450 T	3.25-19	C-Rib	110/90-17	
GS500 E	100/90-19	C906 Hi-Max	120/90-18	C907 Hi-Max
GS500 E/EU	110/70-17		130/70-17	
GS500 F	110/70-17		130/70-17	
GT500	100/90-19	C906 Hi-Max	120/90-18	C907 Hi-Max
RG500 Gamma	110/90-16		120/90-17	
GS550 EM Katana	100/90-19	C906 Hi-Max	120/90-18	C907 Hi-Max
GS550 /L	100/90-19	C906 Hi-Max	120/90-18	C907 Hi-Max
GS550 L/T	100/90-19	C906 Hi-Max	120/90-17	
GSX550 E S/F/U	100/90-16		110/90-18	C907 Hi-Max
GT550	100/90-19	C906 Hi-Max	120/90-18	C907 Hi-Max
GSF600 /S	110/70-17	M6029 Supermaxx Touring	160/60-17	Spuremaxx Sport M6029 Supermaxx Touring
GSF600 /S	120/60-17	Spuremaxx Sport M6029 Supermaxx Touring	160/60-17	Spuremaxx Sport M6029 Supermaxx Touring
GSR600	120/70-17	Spuremaxx Sport M6029 Supermaxx Touring	180/55-17	Spuremaxx Sport M6029 Supermaxx Touring
GSX600 F	120/70-17	Spuremaxx Sport M6029 Supermaxx Touring	150/70-17	M6029 Supermaxx Touring

Motorcycle Fitment Guide

Model	Front	Pattern	Rear	Pattern
Suzuki continued				
GSX-R600	120/70-17	Spuremaxx Sport M6029 Supermaxx Touring	180/55-17	Spuremaxx Sport M6029 Supermaxx Touring
RF600 R	120/70-17	Spuremaxx Sport M6029 Supermaxx Touring	160/60-17	Spuremaxx Sport M6029 Supermaxx Touring
DL650 V-Strom	110/80-19	MA-D Detour	150/70-17	MA-D Detour
GR650	100/90-19	M6011 Classic M6011 Whitewall C906 Hi-Max	130/90-16	M6011 Classic M6011 Whitewall C907 Hi-Max
GS650 G Katana	100/90-19	C906 Hi-Max	130/90-17	C907 Hi-Max
GSF650 /S inc. ABS	120/70-17	Spuremaxx Sport M6029 Supermaxx Touring	160/60-17	Spuremaxx Sport M6029 Supermaxx Touring
GSX650 F	120/70-17	Spuremaxx Sport M6029 Supermaxx Touring	160/60-17	Spuremaxx Sport M6029 Supermaxx Touring
LS650	100/90-19	M6011 Classic M6011 Whitewall C906 Hi-Max	140/90-15	M6011 Whitewall C907 Hi-Max
SFV650 Gladius	120/70-17	Spuremaxx Sport M6029 Supermaxx Touring	160/60-17	Spuremaxx Sport M6029 Supermaxx Touring
SV650 /S	120/60-17	Spuremaxx Sport M6029 Supermaxx Touring	160/60-17	Spuremaxx Sport M6029 Supermaxx Touring
XF650 Freewind	100/90-19	C906 Hi-Max	130/80-17	
GS750 D/E	100/90-19	C906 Hi-Max	120/90-18	C907 Hi-Max
GS750 L Savage	100/90-19	C906 Hi-Max	130/90-17	C907 Hi-Max
GSX750	120/70-17	Spuremaxx Sport M6029 Supermaxx Touring	170/60-17	M6029 Supermaxx Touring
GSX750 E	3.25-19	C-Rib	4.00-18	C180
GSX750 EFE/ESD	100/90-16	C906 Hi-Max	120/90-17	
GSX750 F	120/70-17	Spuremaxx Sport M6029 Supermaxx Touring	150/70-17	M6029 Supermaxx Touring
GSX750 F	110/80-17	M6029 Supermaxx Touring	140/80-17	
GSX750 L	100/90-19	M6011 Classic M6011 Whitewall C906 Hi-Max	130/90-16	M6011 Classic M6011 Whitewall C907 Hi-Max
GSX750 SZ Katana	100/90-19	C906 Hi-Max	120/90-18	C907 Hi-Max
GSX-R750	110/80-18		140/70-18	
GSX-R750	120/70-17	Spuremaxx Sport M6029 Supermaxx Touring	160/60-17	Spuremaxx Sport M6029 Supermaxx Touring
GSX-R750	120/70-17	Spuremaxx Sport M6029 Supermaxx Touring	190/50-17	Spuremaxx Sport M6029 Supermaxx Touring
GSX-R750	120/70-17	Spuremaxx Sport M6029 Supermaxx Touring	180/55-17	Spuremaxx Sport M6029 Supermaxx Touring
GT750	100/90-19	C906 Hi-Max	120/90-18	C907 Hi-Max
VS750 GLP/F	80/90-21	M6011 Classic	140/90-15	M6011 Whitewall C907 Hi-Max
VS750 GLP/F	100/90-19	M6011 Classic M6011 Whitewall C906 Hi-Max	140/90-15	M6011 Whitewall C907 Hi-Max
VL800 Intruder/Volusia	130/90-16	M6011 Classic M6011 Whitewall	170/80-15	M6011 Classic M6011 Whitewall
VS800 GL Intruder	100/90-19	M6011 Classic M6011 Whitewall C906 Hi-Max	140/90-15	M6011 Whitewall C907 Hi-Max
VS800 GL Intruder	80/90-21	M6011 Classic	140/90-15	M6011 Whitewall C907 Hi-Max
VX800	110/80-18		150/70-17	M6029 Supermaxx Touring

Motorcycle Fitment Guide

Model	Front	Pattern	Rear	Pattern
Suzuki continued				
VZ800 /Intruder	130/90-16	M6011 Classic M6011 Whitewall	170/80-15	M6011 Classic M6011 Whitewall
VZ800 Marauder	130/90-16	M6011 Classic M6011 Whitewall	150/90-15	M6011 Classic M6011 Whitewall
GS850 E/G	100/90-19	C906 Hi-Max	130/90-17	C907 Hi-Max
GS850 L	100/90-19	M6011 Classic M6011 Whitewall C906 Hi-Max	130/90-16	M6011 Classic M6011 Whitewall C907 Hi-Max
GS850 L	100/90-19	M6011 Classic M6011 Whitewall C906 Hi-Max	130/90-17	C907 Hi-Max
RF900 R	120/70-17	Spuremaxx Sport M6029 Supermaxx Touring	180/55-17	Spuremaxx Sport M6029 Supermaxx Touring
DL1000 V-Strom	110/80-19	MA-D Detour	150/70-17	MA-D Detour
GS1000 D/E/G	100/90-19	C906 Hi-Max	130/90-17	C907 Hi-Max
GS1000 S (Half fairing)	100/90-19	C906 Hi-Max	120/90-18	C907 Hi-Max
GS1000 L/GL	100/90-19	C906 Hi-Max	130/90-17	C907 Hi-Max
GSX-R1000	120/70-17	Spuremaxx Sport M6029 Supermaxx Touring	190/50-17	Spuremaxx Sport M6029 Supermaxx Touring
GSX-R1000 K8	120/70-17	Spuremaxx Sport M6029 Supermaxx Touring	190/55-17	Supermaxx Sport
GSX-R1000 K9>	120/70-17	Spuremaxx Sport M6029 Supermaxx Touring	190/50-17	Spuremaxx Sport M6029 Supermaxx Touring
SV1000 /S	120/70-17	Spuremaxx Sport M6029 Supermaxx Touring	180/55-17	Spuremaxx Sport M6029 Supermaxx Touring
TL1000 R/S	120/70-17	Spuremaxx Sport M6029 Supermaxx Touring	190/50-17	Spuremaxx Sport M6029 Supermaxx Touring
GS1100 G	100/90-19	C906 Hi-Max	130/90-17	C907 Hi-Max
GSX1100 E/ES	100/90-19	C906 Hi-Max	130/90-17	C907 Hi-Max
GSX1100 E/ES/EF	110/90-16		130/90-17	C907 Hi-Max
GSX1100 G	110/80-18		160/70-17	
GSX1100 L Chopper	100/90-19	M6011 Classic M6011 Whitewall C906 Hi-Max	130/90-16	M6011 Classic M6011 Whitewall C907 Hi-Max
GSX1100 SZ Katana	100/90-19	C906 Hi-Max	130/90-17	C907 Hi-Max
GSX-R1100	110/80-18		160/60-18	
GSX-R1100	120/70-17	Spuremaxx Sport M6029 Supermaxx Touring	160/60-17	Spuremaxx Sport M6029 Supermaxx Touring
GSX-R1100 /W	120/70-17	Spuremaxx Sport M6029 Supermaxx Touring	180/55-17	Spuremaxx Sport M6029 Supermaxx Touring
GSF1200 all models inc. ABS	120/70-17	Spuremaxx Sport M6029 Supermaxx Touring	180/55-17	Spuremaxx Sport M6029 Supermaxx Touring
GSX1200 A3	120/70-17	Spuremaxx Sport M6029 Supermaxx Touring	170/60-17	M6029 Supermaxx Touring
GSF1250 /S/SA	120/70-17	Spuremaxx Sport M6029 Supermaxx Touring	180/55-17	Spuremaxx Sport M6029 Supermaxx Touring
GSX1300 BKA B-Kiing	120/70-17	Spuremaxx Sport M6029 Supermaxx Touring	190/50-17	Spuremaxx Sport M6029 Supermaxx Touring
GSX1300 BKA B-King	120/70-17	Spuremaxx Sport M6029 Supermaxx Touring	200/50/17	M6029 Supermaxx Touring
GSX1300 R Hayabusa	120/70-17	Spuremaxx Sport M6029 Supermaxx Touring	200/50-17	M6029 Supermaxx Touring
GSX1300 R Hayabusa	120/70-17	Spuremaxx Sport M6029 Supermaxx Touring	190/50-17	Spuremaxx Sport M6029 Supermaxx Touring
GSX1400	120/70-17	Spuremaxx Sport M6029 Supermaxx Touring	190/50-17	Spuremaxx Sport M6029 Supermaxx Touring

Motorcycle Fitment Guide

Model	Front	Pattern	Rear	Pattern
Suzuki continued				
VS1400 GL Intruder	110/90-19	M6011 Classic	170/80-15	M6011 Classic M6011 Whitewall
M1500 Intruder	120/70-18	Spuremaxx Sport M6029 Supermaxx Touring	200/50-17	M6029 Supermaxx Touring
VL1500 LC Intruder	150/80-16	M6011 Whitewall	180/70-15	
VZ1600 Marauder	130/70-17		170/60-17	M6029 Supermaxx Touring
C1800 R Intruder	150/80-16	M6011 Whitewall	240/55-16	
M1800 RZ Intruder	130/70-18		240/55-16	
Triumph				
Adventurer T309	110/80-18	C117	150/80-16	C907 Hi-Max
Adventurer T309	100/90-19	C906 Hi-Max	150/80-16	C907 Hi-Max
Bonneville T908	100/90-19	C906 Hi-Max	130/80-17	
Bonneville America T908	3.50-18		170/80-15	
Bonneville SE	110/70-17	M6029 Supermaxx Touring	130/80-17	
Bonneville T100	100/90-19	C906 Hi-Max	130/80-17	
Daytona 600	120/70-17	Supermaxx Sport M6029 Supermaxx Touring	180/55-17	Supermaxx Sport M6029 Supermaxx Touring
Daytona 650	120/70-17	Supermaxx Sport M6029 Supermaxx Touring	180/55-17	Supermaxx Sport M6029 Supermaxx Touring
Daytona 675	120/70-17	Supermaxx Sport M6029 Supermaxx Touring	180/55-17	Supermaxx Sport M6029 Supermaxx Touring
Daytona 750 T300	120/70-17	Supermaxx Sport M6029 Supermaxx Touring	160/60-18	
Daytona 900 T300D	120/70-17	Supermaxx Sport M6029 Supermaxx Touring	180/55-17	Supermaxx Sport M6029 Supermaxx Touring
Daytona 900 T300	120/70-17	Supermaxx Sport M6029 Supermaxx Touring	160/60-18	
Daytona 955i T595	120/70-17	Supermaxx Sport M6029 Supermaxx Touring	190/50-17	Supermaxx Sport M6029 Supermaxx Touring
Daytona/Cent. S/S swing arm 595N	120/70-17	Supermaxx Sport M6029 Supermaxx Touring	190/50-17	Supermaxx Sport M6029 Supermaxx Touring
Daytona Conventional swing arm 595N	120/70-17	Supermaxx Sport M6029 Supermaxx Touring	180/55-17	Supermaxx Sport M6029 Supermaxx Touring
Daytona 1000 T300	120/70-17	Supermaxx Sport M6029 Supermaxx Touring	160/60-18	
Daytona 1000 Super III T300B	120/70-17	Supermaxx Sport M6029 Supermaxx Touring	180/55-17	Supermaxx Sport M6029 Supermaxx Touring
Daytona 1200 T300D	120/70-17	Supermaxx Sport M6029 Supermaxx Touring	180/55-17	Supermaxx Sport M6029 Supermaxx Touring
Daytona 1200 T300	120/70-17	Supermaxx Sport M6029 Supermaxx Touring	160/60-18	
Legend TT T309RT	120/70-17	Supermaxx Sport M6029 Supermaxx Touring	160/60-17	Supermaxx Sport M6029 Supermaxx Touring
Rocket III Touring	150/80-16	M6011 Whitewall	180/70-16	
Scrambler	100/90-19		130/80-17	
Speed Four	120/70-17	Supermaxx Sport M6029 Supermaxx Touring	180/55-17	Supermaxx Sport M6029 Supermaxx Touring
Speed Triple 750 T300C	120/70-17	Supermaxx Sport M6029 Supermaxx Touring	160/60-18	
Speed Triple T300B	120/70-17	Supermaxx Sport M6029 Supermaxx Touring	180/55-17	Supermaxx Sport M6029 Supermaxx Touring
Speed Triple T509	120/70-17	Supermaxx Sport M6029 Supermaxx Touring	190/50-17	Supermaxx Sport M6029 Supermaxx Touring
Speed Triple	120/70-17	Supermaxx Sport M6029 Supermaxx Touring	180/55-17	Supermaxx Sport M6029 Supermaxx Touring

Motorcycle Fitment Guide

Model	Front	Pattern	Rear	Pattern
Triumph continued				
Speedmaster T908	110/80-18		170/80-15	M6011 Classic M6011 Whitewall
Sprint 900 T300A	120/70-17	Supermaxx Sport M6029 Supermaxx Touring	170/60-17	M6029 Supermaxx Touring
Sprint RS T695	120/70-17	Supermaxx Sport M6029 Supermaxx Touring	180/55-17	Supermaxx Sport M6029 Supermaxx Touring
Sprint ST T695	120/70-17	Supermaxx Sport M6029 Supermaxx Touring	180/55-17	Supermaxx Sport M6029 Supermaxx Touring
Sprint ST	120/70-17	Supermaxx Sport M6029 Supermaxx Touring	180/55-17	Supermaxx Sport M6029 Supermaxx Touring
Street Triple (675)	120/70-17	Supermaxx Sport M6029 Supermaxx Touring	180/55-17	Supermaxx Sport M6029 Supermaxx Touring
Thruxton 900	100/90-18	C906 Hi-Max	130/80-17	
Thunderbird T309RT	110/80-18		150/80-16	M6011 Whitewall C907 Hi-Max
Thunderbird Sport T309RT	120/70-17	Supermaxx Sport M6029 Supermaxx Touring	160/60-17	Supermaxx Sport M6029 Supermaxx Touring
Thunderbird 1600	120/70-19		200/50-17	M6029 Supermaxx Touring
Tiger 900 T400	110/80-19	MA-D Detour	140/80-17	
Tiger 900 T709	110/80-19	MA-D Detour	150/70-17	MA-D Detour
Tiger 1050	120/70-17	Supermaxx Sport M6029 Supermaxx Touring	180/55-17	Supermaxx Sport M6029 Supermaxx Touring
Trident 750 T300	120/70-17	Supermaxx Sport M6029 Supermaxx Touring	160/60-18	
Trident 900 T300C	120/70-17	Supermaxx Sport M6029 Supermaxx Touring	160/60-18	
Trident Sprint 900 T300A	120/70-17	Supermaxx Sport M6029 Supermaxx Touring	160/60-18	
Trophy 900 T300	120/70-17	Supermaxx Sport M6029 Supermaxx Touring	160/60-18	
Trophy 900 T300E	120/70-17	Supermaxx Sport M6029 Supermaxx Touring	170/60-17	M6029 Supermaxx Touring
Trophy 1200 T300	120/70-17	Supermaxx Sport M6029 Supermaxx Touring	160/60-18	
Trophy 1200 T300E	120/70-17	Supermaxx Sport M6029 Supermaxx Touring	170/60-17	M6029 Supermaxx Touring
TT600	120/70-17	Supermaxx Sport M6029 Supermaxx Touring	180/55-17	Supermaxx Sport M6029 Supermaxx Touring
Voxan				
Café Racer	120/70-17	Supermaxx Sport M6029 Supermaxx Touring	180/55-17	Supermaxx Sport M6029 Supermaxx Touring
Roadster	120/70-17	Supermaxx Sport M6029 Supermaxx Touring	180/55-17	Supermaxx Sport M6029 Supermaxx Touring
Scrambler	100/90-19		150/70-17	MA-D Detour
Street Scrambler	120/70-17	Supermaxx Sport M6029 Supermaxx Touring	180/55-17	Supermaxx Sport M6029 Supermaxx Touring
Yamaha				
RD50 M/MX	2.50-18	C113	3.00-18	C180
RD80 LC/LCII	2.75-18	C-Rib C117	3.00-18	C180
RD80 MX	2.75-18	C-Rib C117	3.00-18	C180
DT125 X	120/70-17		140/70-17	
RD125	2.50-18	C113	3.00-18	C180
RD125 LC	2.75-18	C-Rib C117	3.00-18	C180

Motorcycle Fitment Guide

Model	Front	Pattern	Rear	Pattern
Yamaha continued				
SR125	3.00-17	C-Rib C180	3.50-16	C155 C289
TDR125	100/90-18		130/80-17	
TW125	130/80-18		180/80-14	
TZR125	110/70-17		140/70-17	
WR125 R	80/90-21		110/80-18	
WR125 X	110/70-17		140/70-17	
XT125 X	100/80-17		130/70-17	
XT125 R	90/90-21		120/80-18	
XV125 Virago	3.00-18	C-Rib C180	130/90-15	C907 Hi-Max
YBR125	2.75-18	C-Rib C117	90/90-18	
YBR125 Custom	3.00-18	C-Rib C180	3.50-16	C117 C289
YZF-R125	100/80-17		130/70-17	
RD250	3.00-18	C-Rib C180	110/80-18	
SR250 SE	3.00-19	C113	120/90-16	C907 Hi-Max
TDR250	100/90-18	C906 Hi-Max	120/80-17	
TZR250	100/80-17		120/80-17	
WR250 X	100/70-17		140/80-17	
XG250 Tricker	80/100-19		120/90-16	C907 Hi-Max
XS250	90/90-18	C906 Hi-Max	110/80-18	
XV250	3.00-18	C-Rib C180	130/90-15	C907 Hi-Max
YBR250	100/80-17		130/70-17	
RD350 /LC/YPVS	90/90-18	C906 Hi-Max	110/80-18	
XS360	90/90-18	C906 Hi-Max	110/80-18	
XS400	90/90-18	C906 Hi-Max	110/80-18	
XS400 SE	3.00-18	C-Rib C180	120/90-16	C907 Hi-Max
RD500 LC	120/80-16	C906 Hi-Max	130/80-18	C907 Hi-Max
SR500	100/90-19	C906 Hi-Max	4.00-18	C180
SR500	100/90-18	C906 Hi-Max	4.00-18	C180
XS500	3.25-19	C-Rib	4.00-18	C180
XV500 SE	3.00-19	C113	130/90-16	M6011 Classic M6011 Whitewall C907 Hi-Max
XV535	3.00-19	C113	140/90-15	M6011 Whitewall C907 Hi-Max
XJ550	3.25-19	C-Rib	110/90-18	C907 Hi-Max
XZ550	90/90-18	C906 Hi-Max	110/80-18	
FZ6 Fazer	120/70-17	Supermaxx Sport M6029 Supermaxx Touring	180/55-17	Supermaxx Sport M6029 Supermaxx Touring
FZR600	120/70-17	Supermaxx Sport M6029 Supermaxx Touring	150/70-18	
FZR600 R	120/60-17	Supermaxx Sport M6029 Supermaxx Touring	160/60-17	Supermaxx Sport M6029 Supermaxx Touring
FZS600 Fazer	110/70-17	M6029 Supermaxx Touring	160/60-17	Supermaxx Sport M6029 Supermaxx Touring
SRX600	100/80-18		120/80-18	C907 Hi-Max
XJ600	90/90-18	C906 Hi-Max	110/90-18	C907 Hi-Max
XJ600 S/N	110/80-17	M6029 Supermaxx Touring	130/70-18	
XJ6 /Diversion/F	120/70-17	Supermaxx Sport M6029 Supermaxx Touring	160/60-17	Supermaxx Sport M6029 Supermaxx Touring

Motorcycle Fitment Guide

Model	Front	Pattern	Rear	Pattern
Yamaha continued				
YZF600 R	120/60-17	Supermaxx Sport M6029 Supermaxx Touring	160/60-17	Supermaxx Sport M6029 Supermaxx Touring
YZF-R6	120/60-17	Supermaxx Sport M6029 Supermaxx Touring	180/55-17	Supermaxx Sport M6029 Supermaxx Touring
XJ650	3.25-19	C-Rib	120/90-18	C907 Hi-Max
XJ650 Turbo	100/90-19	C906 Hi-Max	120/90-18	C907 Hi-Max
XS650	3.25-19	C-Rib	4.00-18	C180
XS650 SE	100/90-19	M6011 Classic M6011 Whitewall C906 Hi-Max	130/90-16	M6011 Classic M6011 Whitewall C907 Hi-Max
XVS650 A	130/90-16	M6011 Classic M6011 Whitewall	170/80-15	M6011 Classic M6011 Whitewall
XVS650 Drag Star	100/90-19	M6011 Classic M6011 Whitewall C906 Hi-Max	170/80-15	M6011 Classic M6011 Whitewall
MT-03	120/70-17	Supermaxx Sport M6029 Supermaxx Touring	160/60-17	Supermaxx Sport M6029 Supermaxx Touring
SZR660	110/70-17	M6029 Supermaxx Touring	150/60-17	
XT600 Z/Tenere	3.00-21		4.60-18	
XT660 R	90/90-21	C6006 Dual Sport Trail M6017 Traxer	130/80-17	C6006 Dual Sport Trail M6017 Traxer
XT660 X	120/70-17	Supermaxx Sport M6029 Supermaxx Touring	160/60-17	Supermaxx Sport M6029 Supermaxx Touring
XT660 Z Tenere	90/90-21	C6006 Dual Sport Trail M6017 Traxer	130/80-17	C6006 Dual Sport Trail M6017 Traxer
FZ750	120/80-16	C906 Hi-Max	130/80-18	C907 Hi-Max
FZ750	120/70-17	Supermaxx Sport M6029 Supermaxx Touring	150/70-18	
FZR750 R	120/70-17	Supermaxx Sport M6029 Supermaxx Touring	160/60-18	
FZX750	110/90-16		150/90-15	
TX750	3.25-19	C-Rib	4.00-18	C180
XJ750	3.25-19	C-Rib	120/90-18	C907 Hi-Max
XJ750	100/90-18	C906 Hi-Max	120/90-18	C907 Hi-Max
XS750 /SE	3.25-19	C-Rib	4.00-18	C180
XV750 SE	100/90-19	M6011 Classic M6011 Whitewall C906 Hi-Max	130/90-16	M6011 Classic M6011 Whitewall C907 Hi-Max
XV750 Virago	100/90-19	M6011 Classic M6011 Whitewall	150/90-15	M6011 Classic M6011 Whitewall
YZF750 R/SP	120/70-17	Supermaxx Sport M6029 Supermaxx Touring	180/55-17	Supermaxx Sport M6029 Supermaxx Touring
YZF-R7	120/70-17	Supermaxx Sport M6029 Supermaxx Touring	180/55-17	Supermaxx Sport M6029 Supermaxx Touring
TDM850	110/80-18		150/70-17	MA-D Detour
TRX850	120/60-17	Supermaxx Sport M6029 Supermaxx Touring	160/60-17	Supermaxx Sport M6029 Supermaxx Touring
XS850	3.25-19	C-Rib	4.00-18	C180
TDM900	120/70-18	Supermaxx Sport M6029 Supermaxx Touring	160/60-17	Supermaxx Sport M6029 Supermaxx Touring
TDM900	120/70-18	Supermaxx Sport M6029 Supermaxx Touring	190/50-17	Supermaxx Sport M6029 Supermaxx Touring
XJ900	100/90-18	C906 Hi-Max	120/90-18	C907 Hi-Max
XJ900 S	120/70-17	Supermaxx Sport M6029 Supermaxx Touring	150/70-17	M6029 Supermaxx Touring

Motorcycle Fitment Guide

Model	Front	Pattern	Rear	Pattern
Yamaha continued				
XV920 SE	100/90-19	M6011 Classic M6011 Whitewall C906 Hi-Max	130/90-16	M6011 Classic M6011 Whitewall C907 Hi-Max
XVS950 A Midnight Star	130/70-18		170/70-16	
FZ1	120/70-17	Supermaxx Sport M6029 Supermaxx Touring	190/50-17	Supermaxx Sport M6029 Supermaxx Touring
FZ1 Fazer ABS	120/70-17	Supermaxx Sport M6029 Supermaxx Touring	180/55-17	Supermaxx Sport M6029 Supermaxx Touring
FZR1000	120/70-17	Supermaxx Sport M6029 Supermaxx Touring	180/55-17	Supermaxx Sport M6029 Supermaxx Touring
FZR1000	120/70-17	Supermaxx Sport M6029 Supermaxx Touring	160/60-18	
FZS1000	120/70-17	Supermaxx Sport M6029 Supermaxx Touring	180/55-17	Supermaxx Sport M6029 Supermaxx Touring
GTS1000 /A	120/70-17	Supermaxx Sport M6029 Supermaxx Touring	180/55-17	Supermaxx Sport M6029 Supermaxx Touring
TR1	3.25-19	C-Rib	120/90-18	C907 Hi-Max
XV1000	100/90-19	M6011 Classic M6011 Whitewall	150/90-15	M6011 Classic M6011 Whitewall
XV1000	100/90-19	M6011 Classic M6011 Whitewall C906 Hi-Max	130/90-16	M6011 Classic M6011 Whitewall C907 Hi-Max
YZF1000 R	120/70-17	Supermaxx Sport M6029 Supermaxx Touring	180/55-17	Supermaxx Sport M6029 Supermaxx Touring
YZF-R1	120/70-17	Supermaxx Sport M6029 Supermaxx Touring	190/50-17	Supermaxx Sport M6029 Supermaxx Touring
YZF-R1	120/70-17	Supermaxx Sport M6029 Supermaxx Touring	190/55-17	Supermaxx Sport
BT1100 Bulldog	120/70-17	Supermaxx Sport M6029 Supermaxx Touring	170/60-17	M6029 Supermaxx Touring
FJ1100	120/80-16	C906 Hi-Max	150/80-16	C907 Hi-Max
XS1100 /S	100/90-19	M6011 Classic M6011 Whitewall C906 Hi-Max	130/90-17	C907 Hi-Max
XV1100	100/90-19	M6011 Classic M6011 Whitewall C906 Hi-Max	150/90-15	M6011 Classic M6011 Whitewall
XVS1100 Drag Star Classic	130/90-16	M6011 Classic M6011 Whitewall	170/80-15	M6011 Classic M6011 Whitewall
XVS1100	110/90-18	M6011 Classic	170/80-15	M6011 Classic M6011 Whitewall
FJ1200	120/80-16	C906 Hi-Max	150/80-16	C907 Hi-Max
FJ1200 /A	120/70-17	Supermaxx Sport M6029 Supermaxx Touring	150/80-16	C907 Hi-Max
V-Max 1200	110/90-18		150/90-15	M6011 Classic M6011 Whitewall
XJR1200	120/70-17	Supermaxx Sport M6029 Supermaxx Touring	180/55-17	Supermaxx Sport M6029 Supermaxx Touring
FJR1300 /A/AS	120/70-17	Supermaxx Sport M6029 Supermaxx Touring	180/55-17	Supermaxx Sport M6029 Supermaxx Touring
XJR1300	120/70-17	Supermaxx Sport M6029 Supermaxx Touring	180/55-17	Supermaxx Sport M6029 Supermaxx Touring
XJR1300	120/70-17	Supermaxx Sport M6029 Supermaxx Touring	190/50-17	Supermaxx Sport M6029 Supermaxx Touring
XVS1300 A Midnight Star	130/90-16	M6011 Classic M6011 Whitewall	170/70-16	



Motorcycle Fitment Guide

Model	Front	Pattern	Rear	Pattern
Yamaha continued				
XVZ1300	130/70-18		140/90-16	M6011 Classic M6011 Whitewall
XVZ1300 A Royal Star	150/80-16	M6011 Whitewall	150/90-15	M6011 Classic M6011 Whitewall
XV1600 Wild Star	130/90-16	M6011 Classic M6011 Whitewall	150/80-16	M6011 Whitewall C907 Hi-Max
MT-01	120/70-17	Supermaxx Sport M6029 Supermaxx Touring	190/50-17	Supermaxx Sport M6029 Supermaxx Touring
V-Max 1700	120/70-18		200/50-18	
XV1700 Road Star Warrior	120/70-18		200/50-17	M6029 Supermaxx Touring
XV1900 A Midnight Star	130/70-18		190/60-17	

Off-Road Fitment Guide

Model	Front	Pattern	Rear	Pattern
Aprilia				
RX50	2.75-21	C858 Premium Trail	4.10-18	C858 Premium Trail
ET50 /Tuareg	2.75-21	C858 Premium Trail	3.50-18	C858 Premium Trail
ETX125	3.00-21	C858 Premium Trail	4.60-18	C858 Premium Trail
ETX350 Tuareg	90/90-21	M6017 Traxer	130/80-17	M6017 Traxer
RXV450/550	90/90-21		140/80-18	
ETX600 Tuareg	90/90-21	M6017 Traxer	130/80-17	M6017 Traxer
Tuareg Wind 600	90/90-21	M6017 Traxer	130/80-17	M6017 Traxer
ETX6.35 Wind	90/90-21	M6017 Traxer	130/80-17	M6017 Traxer
Benelli				
125 BX	2.75-21	C858 Premium Trail	4.10-18	C858 Premium Trail
BMW				
G450 X	90/90-21	C6006 Dual Sport Trail M6017 Traxer	140/80-18	
Cagiva				
WSTX125	2.75-21	C858 Premium Trail	3.50-18	C858 Premium Trail
SX250 Enduro	3.00-21	C858 Premium Trail	4.00-18	C858 Premium Trail
Ala Rossa 350	3.00-21	C858 Premium Trail	4.60-18	C858 Premium Trail
STX350	3.00-21	C858 Premium Trail	4.00-18	C858 Premium Trail
SX350 Enduro	3.00-21	C858 Premium Trail	4.00-18	C858 Premium Trail
CCM				
404 Dual Sport Enduro	90/90-21	C6006 Dual Sport Trail M6017 Traxer	120/90-18	
604 e DS Dual Sport	90/90-21	C6006 Dual Sport Trail M6017 Traxer	120/90-18	
604 e Sport	90/90-21	C6006 Dual Sport Trail M6017 Traxer	120/90-18	
640 e Sport	90/90-21	C6006 Dual Sport Trail M6017 Traxer	120/90-18	
644 Dual Sport Trail	90/90-21	C6006 Dual Sport Trail M6017 Traxer	120/90-18	
Derbi				
Senda 50/R50	2.75-21	C858 Premium Trail C6006 Dual Sport Trail	4.10-18	C858 Premium Trail
Senda Xtreme R50	2.75-21	C858 Premium Trail C6006 Dual Sport Trail	4.10-18	C858 Premium Trail
Senda R125	2.75-21	C858 Premium Trail C6006 Dual Sport Trail	4.10-18	C858 Premium Trail
Ducati				
125 SD	3.00-21	C858 Premium Trail	4.00-18	C186 Premium Trail
125 Enduro	2.75-21	C858 Premium Trail	3.50-18	C858 Premium Trail
Honda				
MT50	2.50-19	C186 Premium Trail	3.00-16	C858 Premium Trail
QR50	2.50-10	M7304 Maxxcross Pro IT	2.50-10	
XL50	2.50-16		2.75-14	
MT80	2.50-19	C186 Premium Trail	3.00-16	C858 Premium Trail
MTX80 /R	2.75-21	C858 Premium Trail	3.50-18	C858 Premium Trail
MTX80 R II	2.75-21	C858 Premium Trail	4.10-18	C858 Premium Trail
TL125 S	3.00-21	C858 Premium Trail	4.00-18	C186 Premium Trail
TL125 /S	3.00-21	C858 Premium Trail	3.25-18	
XL125	2.75-21	C858 Premium Trail	3.50-18	C858 Premium Trail
XLR125	2.75-21	C858 Premium Trail	4.10-18	C858 Premium Trail
XL185 S	2.75-21	C858 Premium Trail	4.10-18	C858 Premium Trail
MTX200 R	2.75-21	C858 Premium Trail	4.10-18	C858 Premium Trail
XL200 R	2.75-21	C858 Premium Trail	4.10-18	C858 Premium Trail
CRF230	2.75-21	C858 Premium Trail	120/80-18	C6006 Dual Sport Trail
NX250	90/100-19		120/90-16	

Off-Road Fitment Guide

Model	Front	Pattern	Rear	Pattern
Honda continued				
XL250 /K3/K4	3.00-21	C858 Premium Trail	4.00-18	C858 Premium Trail
XL250 R	3.00-21	C858 Premium Trail	4.60-17	C858 Premium Trail
XL250 S	3.00-23		4.60-18	C858 Premium Trail
XL350 R	3.00-21	C858 Premium Trail	4.60-17	C858 Premium Trail
CL450	3.25-19		4.00-18	C186 Premium Trail
XL500 R	3.00-21	C858 Premium Trail	4.60-17	C858 Premium Trail
XL500 S	3.00-23		4.60-18	C858 Premium Trail
XL600 R/RM/LM	3.00-21	C858 Premium Trail	5.10-17	
Husaberg				
FE390 e	90/90-21	C6006 Dual Sport Trail M6017 Traxer	140/80-18	
FE400 e	90/90-21	C6006 Dual Sport Trail M6017 Traxer	140/80-18	
FE450 e	90/90-21	C6006 Dual Sport Trail M6017 Traxer	140/80-18	
FE501 e	90/90-21	M7313 Maxxenduro C6006 Dual Sport Trail M6017 Traxer	140/80-18	
FE550 e	90/90-21	C6006 Dual Sport Trail M6017 Traxer	140/80-18	
FE570 e	90/90-21	C6006 Dual Sport Trail M6017 Traxer	140/80-18	
FE600 e	90/90-21	C6006 Dual Sport Trail M6017 Traxer	140/80-18	
FR600 e Rallye	90/90-21	C6006 Dual Sport Trail M6017 Traxer	140/80-18	
FE650 e	90/90-21	C6006 Dual Sport Trail M6017 Traxer	140/80-18	
Husqvarna				
WR125	3.00-21	C858 Premium Trail	4.60-18	C858 Premium Trail
TE250	90/90-21	C6006 Dual Sport Trail	120/80-18	C6006 Dual Sport Trail
WR250	3.00-21	C858 Premium Trail	4.60-18	C858 Premium Trail
WR300	90/90-21	C6006 Dual Sport Trail	140/80-18	
TE310	90/90-21	C6006 Dual Sport Trail	120/80-18	C6006 Dual Sport Trail
TE350	3.00-21	C858 Premium Trail	4.60-18	C858 Premium Trail
WR360	3.00-21	C858 Premium Trail	4.60-18	C858 Premium Trail
TE450	90/90-21	C6006 Dual Sport Trail	140/80-18	
TE510	90/90-21	C6006 Dual Sport Trail	120/90-18	
TE610	3.00-21	C858 Premium Trail	4.60-18	C858 Premium Trail
Hyosung				
RX125	2.75-21	C858 Premium Trail	4.10-18	C858 Premium Trail
Kawasaki				
AE50	2.50-19	C186 Premium Trail	3.00-16	C858 Premium Trail
AE80	2.50-19	C186 Premium Trail	3.00-16	C858 Premium Trail
KE125	2.75-21	C858 Premium Trail	3.50-18	C858 Premium Trail
KMX125	2.75-21	C858 Premium Trail	4.10-18	C858 Premium Trail
KE175	2.75-21	C858 Premium Trail	3.50-18	C858 Premium Trail
KMX200	3.00-21	C858 Premium Trail	4.60-17	C858 Premium Trail
KL250 A	3.00-21	C858 Premium Trail	4.00-18	C186 Premium Trail
KLR250 D	3.00-21	C858 Premium Trail	4.60-17	C858 Premium Trail
KLX250 B	3.00-21	C858 Premium Trail	4.60-18	C858 Premium Trail
KTM				
125 EXC 2T	90/90-21		120/90-18	
125 EXE	3.00-21		4.60-18	C858 Premium Trail
200 EXC 2T	90/90-21	M6017 Traxer C6006 Dual Sport Trail	120/90-18	

Off-Road Fitment Guide

Model	Front	Pattern	Rear	Pattern
KTM continued				
250/300 EXC 2T	90/90-21	M6017 Traxer C6006 Dual Sport Trail	140/80-18	
250 EXC Racing 4T	90/90-21	M6017 Traxer C6006 Dual Sport Trail	120/90-18	
400 LC4 4T	90/90-21	M6017 Traxer C6006 Dual Sport Trail	130/80-18	
450 EXC Racing 4T	90/90-21	M6017 Traxer C6006 Dual Sport Trail	140/80-18	
525 EXC Racing 4T	90/90-21	M6017 Traxer C6006 Dual Sport Trail	140/80-18	
530 EXC	90/90-21	M6017 Traxer C6006 Dual Sport Trail	120/90-18	
620 LC4 Supercompetition	90/90-21	M6017 Traxer C6006 Dual Sport Trail	130/80-18	
620 LC4 Competition 4T	90/90-21	M6017 Traxer C6006 Dual Sport Trail	130/80-18	
620 LSE	100/90-19		130/80-17	M6017 Traxer
625 SXC 4T	90/90-21	M6017 Traxer C6006 Dual Sport Trail	140/80-18	
640 LC4 - E 4T	90/90-21	M6017 Traxer C6006 Dual Sport Trail	130/80-18	
640 LC4 Adventure 4T	90/90-21	M6017 Traxer C6006 Dual Sport Trail	130/80-18	
690 Enduro LC4	90/90-21	M6017 Traxer C6006 Dual Sport Trail	140/80-18	
950 Adventurer LC8	90/90-21	M6017 Traxer C6006 Dual Sport Trail	160/60-18	
950 Super Enduro R	90/80-21		140/80-18	
990 Adventurer LC8	90/90-21	M6017 Traxer C6006 Dual Sport Trail	160/60-18	
Kymco				
Stryker 125	90/90-21	M6017 Traxer C6006 Dual Sport Trail	130/80-17	M6017 Traxer C6006 Dual Sport Trail
Morini				
125 Kanguro KJ	2.75-21	C858 Premium Trail	4.10-18	C858 Premium Trail
350 Kanguro	3.00-21	C858 Premium Trail	4.00-18	C858 Premium Trail
501/2 Camel	3.00-21	C858 Premium Trail	4.00-18	C858 Premium Trail
501 Coguaro	3.00-21	C858 Premium Trail	4.00-18	C858 Premium Trail
MZ/MuZ				
125 SX	90/90-21	C6006 Dual Sport Trail	120/80-18	C6006 Dual Sport Trail
Suzuki				
TS80 ER	2.75-21	C858 Premium Trail	3.00-18	C858 Premium Trail
TS80 X	2.75-21	C858 Premium Trail	3.25-18	
DR125 S/SE/U	70/100-21		90/90-18	
DR250 S	3.00-21	C858 Premium Trail	4.00-18	C186 Premium Trail
TS250 ER	3.00-21	C858 Premium Trail	4.60-18	C858 Premium Trail
TS250 X	3.00-21	C858 Premium Trail	130/80-17	C6006 Dual Sport Trail
DR350 N Sport	90/90-21	M6017 Traxer C6006 Dual Sport Trail	120/90-18	
DR350 S/SH	90/90-21	M6017 Traxer C6006 Dual Sport Trail	120/90-18	
SP370	3.00-21	C858 Premium Trail	4.00-18	C186 Premium Trail
SR370	3.00-21	C858 Premium Trail	4.00-18	C186 Premium Trail
DR400 S	3.00-21	C858 Premium Trail	4.60-18	C858 Premium Trail
DR-Z 400 S/BE	90/90-21	M6017 Traxer C6006 Dual Sport Trail	120/90-18	

Off-Road Fitment Guide

Model	Front	Pattern	Rear	Pattern
Suzuki continued				
DR500 S	3.00-21	C858 Premium Trail	4.00-18	C186 Premium Trail
DR600 R/RU/S/SU	90/90-21	M6017 Traxer	130/80-17	M6017 Traxer
VS600 GLP	80/90-21		140/90-15	
DR650 all models	90/90-21	M6017 Traxer	120/90-17	
DR750 S/SU	90/90-21	M6017 Traxer	130/80-17	M6017 Traxer
DR800 S/SU	90/90-21	M6017 Traxer	130/80-17	M6017 Traxer
Yamaha				
PW50	2.50-10	M7304 Maxxcross Pro IT	2.50-10	M7304 Maxxcross Pro IT
TTR50 E	2.50-10	M7304 Maxxcross Pro IT	2.50-10	M7304 Maxxcross Pro IT
DT80 LC/LCII	2.75-21	C858 Premium Trail	4.10-18	C858 Premium Trail
PW80	2.50-14		3.00-12	
DT125 /R	2.75-21	C6006 Dual Sport Trail C858 Premium Trail	4.10-18	C858 Premium Trail
XT125 R	90/90-21	C6006 Dual Sport Trail	120/80-18	C6006 Dual Sport Trail
DT175 MX	2.75-21	C858 Premium Trail	4.10-18	C858 Premium Trail
TW200	130/80-18		180/80-14	
DT250	3.00-21	C858 Premium Trail	4.00-18	C858 Premium Trail
XT250	3.00-21	C858 Premium Trail	4.60-17	C858 Premium Trail
XT350	3.00-21	C858 Premium Trail	110/80-18	
XT350	3.00-21	C858 Premium Trail	4.10-18	C858 Premium Trail
DT400	3.00-21	C858 Premium Trail	4.00-18	C186 Premium Trail
XT500	90/90-18		4.00-18	C186 Premium Trail
XT550	3.00-21	C858 Premium Trail	4.60-18	C858 Premium Trail
TT600	90/90-21	C6006 Dual Sport Trail M6017 Traxer M7313 Maxxenduro	140/80-18	
TT600 E/S/R	90/90-21	C6006 Dual Sport Trail M6017 Traxer	130/80-18	C6006 Dual Sport Trail
XT600	3.00-21	C858 Premium Trail	4.60-18	C858 Premium Trail
XT600 E/K	90/90-21	C6006 Dual Sport Trail M6017 Traxer	120/90-17	
XTZ660	90/90-21	C6006 Dual Sport Trail M6017 Traxer	120/90-17	
XTZ750	90/90-21	M6017 Traxer C6006 Dual Sport Trail	140/80-17	M6017 Traxer

Scooter Fitment Guide

Model	Front Tyre Size	Pattern	Rear Tyre Size	Pattern
Aprilia				
Amico 50 all models	100/90-10	M6029	100/90-10	M6029
Gulliver 50	120/70-12	M6029	120/70-12	M6029
Habana 50 /Custom	120/70-12	M6029	130/70-12	M6029
Mojito 50 /Custom	120/70-12	M6029	130/70-10	M6029
Rally 50 AC	120/90-10	M6029	130/90-10	M6029
		C923		
Rally 50 LC	120/70-12	M6029	140/70-12	M6029
Sonic 50 AC/LC	100/90-10	M6029	100/90-10	M6029
SR50 all models	130/60-13	M6029	130/60-13	M6029
Area 51	130/60-13	M6029	130/60-13	M6029
Atlantic 125	110/90-13	M6029	130/70-13	M6029
Habana 125 /Custom	120/70-12	M6029	130/70-10	M6029
Leonardo 125	120/70-12	M6029	140/70-12	M6029
Mojito 125 /Custom	120/70-12	M6029	130/70-10	M6029
SR125	130/60-13	M6029	130/60-13	M6029
Leonardo 150	120/70-12	M6029	140/70-12	M6029
Atlantic 200/250	110/90-13	M6029	130/70-13	M6029
Leonardo 250/300	130/70-12	M6029	130/70-12	M6029
BMW				
C1	120/70-13	M6029	140/70-12	M6029
Cagiva				
City 50	90/90-10	M6029	90/90-10	M6029
		C922		C922
Passing 110	90/90-10	M6029	90/90-10	M6029
		C922		C922
Super City 125	110/70-17	M6029	150/60-17	
Daelim				
Cordi 50	90/90-10	M6029	90/90-10	M6029
		C922		C922
E-Five ATS/Majo 50	130/90-10	M6029	130/90-10	M6029
		C924		C924
Delfino 100	100/90-10	M6029	100/90-10	M6029
History/Forte 125	120/70-12	M6029	130/70-12	M6029
S-Five Major 125	120/70-12	M6029	130/70-12	M6029
S2 125/250	120/70-12	M6029	130/70-12	M6029
Gilera				
Runner 50	120/70-12	M6029	130/70-12	M6029
Stalker 50	120/90-10	M6029	130/90-10	M6029
		C923		C924
Runner 125	120/70-12	M6029	130/70-12	M6029
Super Runner	120/70-15	M6002	160/60-14	
		M6128		
TPH125 /X	120/90-10	M6029	120/90-10	M6029
		C923		C923
Runner 180	120/70-12	M6029	130/70-12	M6029
Nexus 250/350	120/70-15	M6002	160/60-14	
		M6128		
Honda				
Chaly CF50	3.50-10	C131	3.50-10	C131
Dax ST50 /G	3.50-10	C131	3.50-10	C131
NH50 Lead	3.50-10	C131	3.50-10	C131
SA50 Vision	3.50-10	C131	3.50-10	C131
SFX50	90/90-10	M6029	90/90-10	M6029
		C922		C922
SJ50 Bali	100/90-10	M6029	100/90-10	M6029

Scooter Fitment Guide

Model	Front Tyre Size	Pattern	Rear Tyre Size	Pattern
Honda continued				
SXR50	90/90-10	M6029 C922	90/90-10	M6029 C922
X8 R	120/70-13	M6029	140/60-13	M6029
X8 R	120/80-12	M6029	120/80-12	M6029
ZB50	3.50-10	C131 C910	3.50-10	C131 C910
ZB50 Monkey Z50 J	3.50-8		3.50-8	
Dax ST70	3.50-10	C131 C910	3.50-10	C131 C910
CY80	5.40-10		5.40-10	
NH80 Lead	3.50-10	C131 C910	3.50-10	C131 C910
SJ100 Bali	100/90-10	M6029	100/90-10	M6029
@125	110/90-13	M6029	130/70-13	M6029
Lead 125	3.50-10	C131	3.50-10	C131 C910
NES125	110/90-13	M6029	130/70-13	M6029
New Pantheon	110/90-13	M6029	130/70-12	M6029
Pantheon 125	110/90-12	M6029	130/70-12	M6029
Foresight 250	110/90-12		130/70-12	M6029
Helix	110/100-12		120/90-10	M6029 C923
SH300	110/70-16	M6135	130/70-16	M6029
Silver Wing inc. ABS	120/80-14		150/70-13	M6029
Kymco				
Dink 50	120/70-12	M6029	130/70-12	M6029
DJ50 Refined	3.00-10	C131	3.00-10	C131
Super 9	120/70-12	M6029	130/70-12	M6029
Top Boy Cross	120/90-10	M6029 C923	130/90-10	M6029 C924
Yager 50	120/70-12	M6029	130/70-12	M6029
Dink 125	120/70-12	M6029	130/70-12	M6029
Grand Dink 125	120/70-12	M6029	140/70-12	M6029
Movie 125 XL	120/70-12	M6029	130/70-12	M6029
Yager 125	120/70-12	M6029	130/70-12	M6029
MBK				
Booster	120/90-10	M6029 C923	130/90-10	M6029 C924
Nitro 50/100	130/60-13	M6029	140/60-13	M6029
Ovetto 50	120/70-12	M6029	130/70-12	M6029
Ovetto 100	120/90-10	M6029 C923	130/90-10	M6029 C924
Doodo 125	120/70-12	M6029	130/70-12	M6029
Flame 125	3.50-10	C131 C910	3.50-10	C131 C910
Skyliner 125 R	120/70-12	M6029	130/70-12	M6029
Thunder 125	120/70-12	M6029	130/70-12	M6029
MZ/MuZ				
Moskito 125	120/70-12	M6029	130/70-12	M6029
Peugeot				
Elyseo 50	120/70-12	M6029	120/70-12	M6092
Speedfight 50	120/70-12	M6029	130/70-12	M6092
Trekker Off Road 50	120/90-10	M6029 C923	130/70-10	M6092
Trekker Road 50	120/70-12	M6029	130/70-12	M6092
Vivacity 50	120/70-12	M6029	130/70-12	M6092

Scooter Fitment Guide

Model	Front Tyre Size	Pattern	Rear Tyre Size	Pattern
Peugeot continued				
Zenith 50	90/90-10	M6029 C922	90/90-10	M6092 C922
Elyseo 100	120/70-12	M6029	130/70-12	M6092
Speedfight 100	120/70-12	M6029	140/70-12	M6092
Trekker Road 100	120/70-12	M6029	130/70-12	M6092
Vivacity 100	120/70-12	M6029	130/70-12	M6092
Elyseo 125	120/70-12	M6029	130/70-12	M6092
Piaggio/Vespa				
ET2 Injection	100/80-10	M6029	100/80-10	M6029
NRG50	130/60-13	M6029	130/60-13	M6029
NRG Power 50 all models	120/70-13	M6029	140/60-13	M6029
PK50 S	3.00-10	C131	3.00-10	C131
Quartz 50	100/80-10	M6029	100/80-10	M6029
Sfera 50	90/90-10	M6029 C922	100/80-10	M6029
TPH50	120/90-10	M6029 C923	120/90-10	M6029 C923
Zip 25/50	100/80-10	M6029	100/80-10	M6029
PK80 S	3.00-10	C131	3.00-10	C131
PX80 E	3.50-10	C131	3.50-10	C131
Sfera 80	90/90-10	M6029 C922	100/80-10	M6029
Carnaby 125	110/70-16	M6135	130/70-16	
Cosa 125	100/90-10	M6029	100/90-10	M6029
GT5 125	3.50-10	C131	3.50-10	C131
PK125 S	3.00-10	C131	3.00-10	C131
PX125/150	100/80-10	M6029	120/90-10	M6029 C923
Skipper 125 LX	120/70-12	M6029	130/70-12	M6029
SKR125	100/80-10	M6029	110/80-10	M6029
TPH125	120/90-10	M6029 C923	120/90-10	M6029 C923
X Evo 125	120/70-14	M6112	130/70-12	M6029
X8 125	120/70-14	M6112	130/70-12	M6029
Gespann	3.50-10	C131	3.50-10	C131
PX200	3.50-10	C131	3.50-10	C131
Cosa 200	100/90-10	M6029	100/90-10	M6029
GT5 S 200	3.50-10	C131	3.50-10	C131
Suzuki				
AH50 Address	90/90-10	M6029 C922	3.00-10	C131
AP50	100/90-10	M6029	120/90-10	M6029 C923
AP50	100/80-10	M6029	100/80-10	M6029
AY50 Katana	120/70-12	M6029	130/70-12	M6029
AY50 W/WR Katana	120/70-12	M6029	130/60-13	M6029
CP50 Roller	3.00-10	C131	90/90-10	M6029 C922
CS50 Roller	3.00-10	C131	3.00-10	C131
RV50	5.40-10		5.40-10	
TR50 S Street Magic	120/70-12	M6029	130/70-12	M6029
UF50 Estilete	120/70-12	M6029	130/70-12	M6029
UX50 W Zillion	120/70-12	M6029	130/70-12	M6029
UG110	90/90-12	M6029 C922	100/80-12	
AN125	3.50-10	C131	100/90-10	M6029

Scooter Fitment Guide

Model	Front Tyre Size	Pattern	Rear Tyre Size	Pattern
Suzuki continued				
Sixteen 125	100/80-16	M6120	120/80-16	M6128
UE125	100/90-10	M6029	100/90-10	M6029
UH125 Burgman	110/90-12		130/70-12	M6029
UH125 Burgman	110/90-13	M6029	130/70-12	M6029
UH200 Burgman	110/90-12		130/70-12	M6029
UH200 Burgman	110/90-13	M6029	130/70-12	M6029
AN250 Burgman	120/80-14		150/70-13	
AN250 Burgman	110/90-13	M6029	130/70-13	M6029
AN400 Burgman	110/90-13	M6029	130/70-13	M6029
AN400 Burgman	120/80-14		150/70-13	
AN650 Burgman	120/70-15	M6002 M6128	160/60-14	
Yamaha				
Aerox R 50	130/60-13	M6029	140/60-13	M6029
Breeze 50	100/90-10	M6029	100/90-10	M6029
BW's 50 /R	120/90-10	M6029 C923	130/90-10	M6029 C924
CA50	3.00-10	C131	3.00-10	C131
CW50 Spy RSP	120/70-12	M6029	130/70-12	M6029
Giggle 50	120/90-10	M6029 C923	120/90-10	M6029 C923
JogRR 50	110/70-12		120/70-12	M6029
Neo's 4 50	120/70-12	M6029	130/70-12	M6029
Slider 50	120/80-12	M6029	130/90-10	M6029 M924
YA50 R Axis	100/80-10	M6029	100/80-10	M6029
YE50 Zest	90/90-10	M6029 C922	100/80-10	M6029
YE50 Zest Evolis	100/90-10	M6029	100/90-10	M6029
YN50 /R Neo's	120/70-12	M6029	130/70-12	M6029
YQ50 Aerox	130/60-13	M6029	140/60-13	M6029
Zest 80	100/80-10	M6029	100/80-10	M6029
BW's 100	120/90-10	M6029 C923	130/90-10	M6029 C924
QY100 Aerox	130/60-13	M6029	140/60-13	M6029
YN100 Neo's	120/70-12	M6029	130/70-12	M6029
BL125	3.50-10	C131 C910	3.50-10	C131 C910
BW's 125	120/70-12	M6029	130/70-12	M6029
Cygnus X 125	110/70-12		120/70-12	M6029
Vity 125	100/90-10	M6029	100/90-10	M6029
XC125	100/90-10	M6029	100/90-10	M6029
X-max 125	120/70-15	M6002 M6128	140/70-14	M6112
YP125 R Majesty	120/70-12	M6029	130/70-12	M6029
XC180	3.50-10	C131 C910	4.00-10	
YP250 D	110/90-12		130/70-12	M6029
X-max 250	120/70-15	M6002 M6128	140/70-14	M6112
Versity 300	120/80-14		150/70-14	M6112
XP500 Tmax	120/70-14	M6112	160/60-15	
XP500 Tmax	120/70-14	M6112	150/70-14	M6112

ATV Fitment Guide

Model	Front Tyre Size	Pattern	Rear Tyre Size	Pattern
Honda				
TRX250 EX Sportrax	22 x 7.00-10	M943 iRazr Radial M933 Razr2 M931 Razr	22 x 10.00-9	
TRX400 EX Sportrax	22 x 7.00-10	M943 iRazr Radial M933 Razr2 M931 Razr	22 x 10.00-9	
TRX420 FM/FE/FA Fourtrak 4x4	24 x 8.00-12	C828 Wildcat	24 x 10.00-11	C828 Wildcat M9208 Sur Trak
TRX420 TM/TE Fourtrak 2x4	24 x 8.00-12	C828 Wildcat	24 x 10.00-11	C828 Wildcat M9208 Sur Trak
TRX450 R Sportrax	22 x 7.00-10	M943 iRazr Radial M933 Razr2 M931 Razr	22 x 10.00-9	
TRX450 ER Sportrax	21 x 7.00-10	C9272 Streetmaxx M943 iRazr Radial M933 Razr2 M931 Razr	20 x 10.00-9	C9273 Streetmaxx
TRX500 FM/FE/FA Forman 2/4x4	25 x 8.00-12	M917 Bighorn Radial C828 Wildcat M9208 Sur Trak C9272 Streetmaxx	25 x 10.00-12	M918 Bighorn Radial C828 Wildcat M9208 Sur Trak C9273 Streetmaxx
TRX680 FA Rincon 2/4x4	25 x 8.00-12	M917 Bighorn Radial C828 Wildcat M9208 Sur Trak C9272 Streetmaxx	25 x 10.00-12	M918 Bighorn Radial C828 Wildcat M9208 Sur Trak C9273 Streetmaxx
TRX700 XX Sportrax	21 x 7.00-10	C9272 Streetmaxx M943 iRazr Radial M933 Razr2 M931 Razr	22 x 9.00-11	
Kawasaki				
KLF300 4x4	24 x 8.00-11	C828 Wildcat M9208 Sur Trak	24 x 10.00-11	C828 Wildcat M9208 Sur Trak
KVF360 4x4	25 x 8.00-12	M917 Bighorn Radial C828 Wildcat M9208 Sur Trak C9272 Streetmaxx	25 x 10.00-12	M918 Bighorn Radial C828 Wildcat M9208 Sur Trak C9273 Streetmaxx
Mule 610 4x4	24 x 9.00-10		24 x 11.00-10	C828 Wildcat
KVF650 4x4	25 x 8.00-12	M917 Bighorn Radial C828 Wildcat M9208 Sur Trak C9272 Streetmaxx	25 x 10.00-12	M918 Bighorn Radial C828 Wildcat M9208 Sur Trak C9273 Streetmaxx
KFX700	22 x 7.00-10	M943 iRazr Radial M933 Razr2 M931 Razr	22 x 11.00-10	M934 Razr2 C828 Wildcat M9208 Sur Trak
KVF750 4x4	25 x 8.00-12	M917 Bighorn Radial C828 Wildcat M9208 Sur Trak C9272 Streetmaxx	25 x 10.00-12	M918 Bighorn Radial C828 Wildcat M9208 Sur Trak C9273 Streetmaxx
Suzuki				
LT-Z50 QuadSport	16 x 8.00-7	C829	16 x 8.00-7	C829
LT-Z90 QuadSport	19 x 7.00-8	C9272 Streetmaxx	19 x 7.00-8	C9272 Streetmaxx
LT-Z250 QuadSport	22 x 7.00-10	M943 iRazr Radial M933 Razr2 M931 Razr	20 x 10.00-9	

ATV Fitment Guide

Model	Front Tyre Size	Pattern	Rear Tyre Size	Pattern
Suzuki continued				
KingQuad 400 Manual/Auto	25 x 8.00-12	M917 Bighorn Radial C828 Wildcat C9272 Streetmaxx	25 x 10.00-12	M918 Bighorn Radial C828 Wildcat C9273 Streetmaxx M9208 Sur Trak
LT-Z400 QuadSport	22 x 7.00-10	M943 iRazr Radial M933 Razr2 M931 Razr	20 x 10.00-9	
KingQuad 450	25 x 8.00-12	M917 Bighorn Radial C828 Wildcat C9272 Streetmaxx	25 x 10.00-12	M918 Bighorn Radial C828 Wildcat C9273 Streetmaxx M9208 Sur Trak
KingQuad 500 Power Steering	25 x 8.00-12	M917 Bighorn Radial C828 Wildcat C9272 Streetmaxx	25 x 10.00-12	M918 Bighorn Radial C828 Wildcat C9273 Streetmaxx M9208 Sur Trak
KingQuad 750 /Power Steering	25 x 8.00-12	M917 Bighorn Radial C828 Wildcat C9272 Streetmaxx	25 x 10.00-12	M9208 Sur Trak C828 Wildcat C9273 Streetmaxx
Yamaha				
Big Bear 250	22 x 7.00-10	M943 iRazr Radial M933 Razr2 M931 Razr	22 x 10.00-10	C9273 Streetmaxx
Grizzly 350 2x4	25 x 8.00-12	M917 Bighorn Radial C828 Wildcat M9208 Sur Trak C9272 Streetmaxx	25 x 10.00-12	M918 Bighorn Radial C828 Wildcat M9208 Sur Trak C9273 Streetmaxx
Grizzly 350 4x4 /WVTA/IRS	25 x 8.00-12	M917 Bighorn Radial C828 Wildcat M9208 Sur Trak C9272 Streetmaxx	25 x 10.00-12	M918 Bighorn Radial C828 Wildcat M9208 Sur Trak C9273 Streetmaxx
YFM350 R WVTA	21 x 7.00-10	M943 iRazr Radial M933 Razr2 M931 Razr C873	20 x 10.00-9	C9273 Streetmaxx
Grizzly 450 IRS	25 x 8.00-12	M917 Bighorn Radial C828 Wildcat M9208 Sur Trak C9272 Streetmaxx	25 x 10.00-12	M918 Bighorn Radial C828 Wildcat M9208 Sur Trak C9273 Streetmaxx
YFZ450 R	21 x 7.00-10	M943 iRazr Radial M933 Razr2 M931 Razr C9272 Streetmaxx C873	20 x 10.00-9	C9273 Streetmaxx
Grizzly 550 EPS	25 x 8.00-12	M917 Bighorn Radial C828 Wildcat M9208 Sur Trak C9272 Streetmaxx	25 x 10.00-12	M918 Bighorn Radial C828 Wildcat M9208 Sur Trak C9273 Streetmaxx
Grizzly 700 EPS	25 x 8.00-12	M917 Bighorn Radial C828 Wildcat M9208 Sur Trak C9272 Streetmaxx	25 x 10.00-12	M918 Bighorn Radial C828 Wildcat M9208 Sur Trak C9273 Streetmaxx
YFM700 R	21 x 7.00-10	M943 iRazr Radial M933 Razr2 M931 Razr C9272 Streetmaxx C873	20 x 10.00-9	C9273 Streetmaxx



Maxxis International UK plc
Carr Road, Felixstowe, Suffolk IP11 3RX
Telephone: 01394 604040
Facsimile: 01394 604041
www.maxxis.co.uk
sales@maxxis.co.uk